

## Range 30"

CPF30UGGAN  
 Anthracite  
 Full Gas

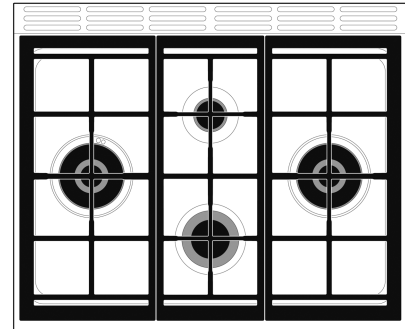

### Cooktop technical features

Cooking zones	4
Left - Gas - Dual ultra-rapid - 20000 BTU	
Front-center - Gas - Semi-rapid - 8000 BTU	
Rear-center - AUX - 4500 BTU	
Right - Gas - Ultra-rapid - 20000 BTU	
Automatic gas ignition	Yes
Gas safety valves	Yes

### Aesthetic

Color	Anthracite
-------	------------

### General information

Range size	30"
Range type	Full Gas

### Programs / Functions

No. of cooking functions	2
--------------------------	---

### Main oven options

Minimum Temperature	120 °F
Maximum temperature	500 °F

### Main Oven Technical Features

Volume	0.13 cu. ft.
Cavity material	EverClean enamel
No. of shelves	4
Removable inner door	Yes
Total no. of door glasses	3
Soft Close system	Yes

Compact- design range with gas oven and gas cooktop: efficient and responsive, the visible heat source allows total control and choice of the right intensity.

### Features

- Touch control** - Easy and intuitive timer setting with a single touch
- Tangential cooling** - New cooling system with tangential fan and airflow from the door to the splashback
- Gas hob** - Gas provides permanent control of the heat source and the temperature change is immediate
- Soft close** - The door is equipped with a specific system for silent closing

## Included accessories

Oven wire rack 1

## Electrical Connection

Circuit breaker 15 A  
 Voltage 120 V  
 Frequency 60 Hz

## Logistic Information

Width 29 15/16 "  
 Depth 25 3/16 "  
 Height 35 7/16 "  
 Net weight 235 lbs

## Product dimension drawing

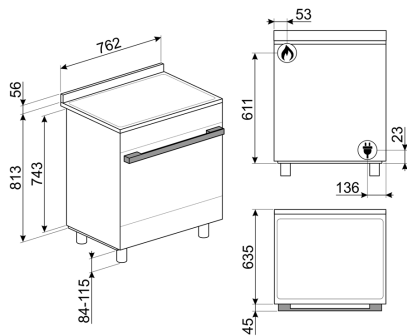

## Product installation drawing

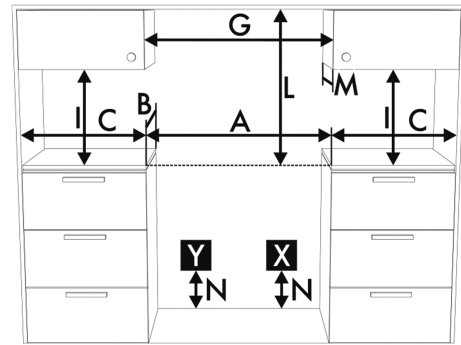

A	1220 mm	48 1/16"
B	636 mm	25"
C <sup>1</sup>	216 mm	8 1/2"
G <sup>2</sup>	1220 mm	48 1/16"
I <sup>3</sup>	457 mm	18"
L <sup>4</sup>	610 mm	24"
M <sup>5</sup>	330 mm	13"
N	178 mm	7"

## Accessories



GT91P

Partially extractable telescopic guides suitable for 90 cm Master and Sinfonia cookers



PALPZ

Pizza shovel with fold away handle

## Color option



CPF30UGGR  
 Color: Red



CPF30UGGWH  
 Color: White