

Range 30"

CPF30UGMAN
Anthracite
Dual-Fuel

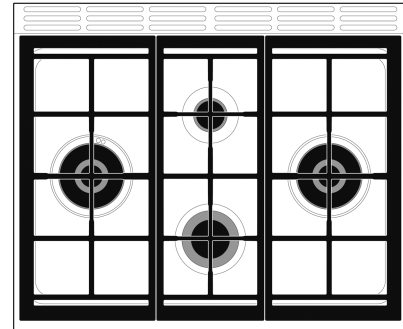

Cooktop technical features

Cooking zones	4
Left - Gas - Dual ultra-rapid - 20000 BTU	
Front-center - Gas - Semi-rapid - 8000 BTU	
Rear-center - AUX - 4500 BTU	
Right - Gas - Ultra-rapid - 20000 BTU	
Automatic gas ignition	Yes
Gas safety valves	Yes

Aesthetic

Color	Anthracite
-------	------------

General information

Range size	30"
Range type	Dual-Fuel

Programs / Functions

No. of cooking functions	9
--------------------------	---

Main oven options

Minimum Temperature	120 °F
Maximum temperature	500 °F

Main Oven Technical Features

Volume	0.13 cu. ft.
Cavity material	EverClean enamel
No. of shelves	4
Removable inner door	Yes
Total no. of door glasses	3
Soft Close system	Yes

Compact- design range with electric oven and gas cooktop: efficient and responsive, the visible heat source allows total control and choice of the right intensity.

Features

Touch control - Easy and intuitive timer setting with a single touch

Tangential cooling - New cooling system with tangential fan and airflow from the door to the splashback

True-convection - The best cooking performances guaranteed by ventilated circular flow.

Gas hob - Gas provides permanent control of the heat source and the temperature change is immediate

Included accessories

Oven wire rack 1

Electrical Connection

Circuit breaker 20 A
 Voltage 240/208 V
 Frequency 60 Hz

Logistic Information

Width 30 "
 Depth 25 "
 Height 36 "
 Net weight 233 lbs

Product dimension drawing

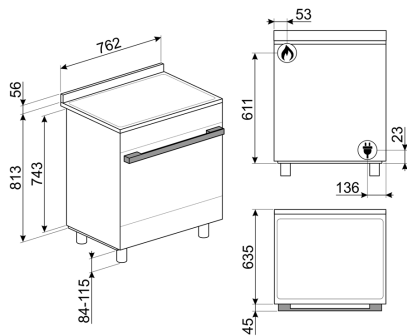

Product installation drawing

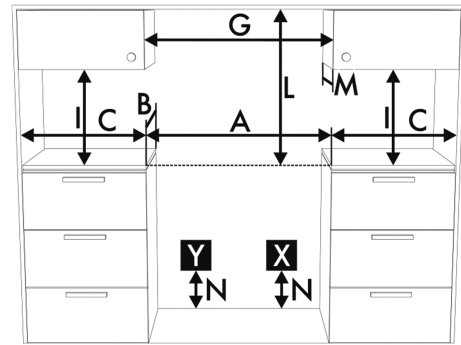

A	1220 mm	48 1/16"
B	636 mm	25"
C ¹	216 mm	8 1/2"
G ²	1220 mm	48 1/16"
I ³	457 mm	18"
L ⁴	610 mm	24"
M ⁵	330 mm	13"
N	178 mm	7"

Accessories



GT91P
 Partially extractable telescopic guides suitable for 90 cm Master and Sinfonia cookers



PALPZ
 Pizza shovel with fold away handle