

## Range 30"

CPF30UGMX  
Stainless steel  
Portofino

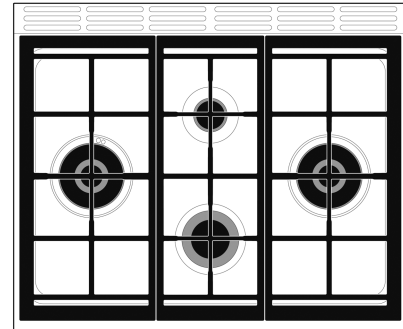

### Cooktop technical features

Cooking zones	4
Left - Gas - Dual ultra-rapid - 20000 BTU	
Rear-center - Gas - Semi-rapid - 8000 BTU	
Front-center - AUX - 4500 BTU	
Right - Gas - Ultra-rapid - 20000 BTU	
Automatic gas ignition	Yes
Gas safety valves	Yes

### Programs / Functions

No. of cooking functions	9
--------------------------	---

### Main oven options

Minimum Temperature	120 °F
Maximum temperature	500 °F

Compact- design cooker with electric oven and gas hob: efficient and responsive, the visible heat source allows total control and choice of the right intensity.

### Features

**Gas hob** - Gas provides permanent control of the heat source and the temperature change is immediate

**Touch control** - Easy and intuitive timer setting with a single touch

**Storage compartment** - More space thanks to the lower compartment, ideal for storing accessories or cooking utensils

**True-convection** - The best cooking performances guaranteed by ventilated circular flow.

**Tangential cooling** - New cooling system with tangential fan and airflow from the door to the splashback

**Soft close** - The door is equipped with a specific system for silent closing

### Main Oven Technical Features

Volume	0.13 cu. ft.
Cavity material	EverClean enamel
No. of shelves	4
Removable inner door	Yes
Total no. of door glasses	3
Soft Close system	Yes

### Included accessories

Oven wire rack	1
----------------	---

### Electrical Connection

Plug	No
Circuit breaker	20 A
Voltage	240/208 V
Frequency	60 Hz

## Logistic Information

Width	30 1/16 "
Depth	25 1/16 "
Height	36 1/16 "
Net weight	232 lbs

## Product dimension drawing

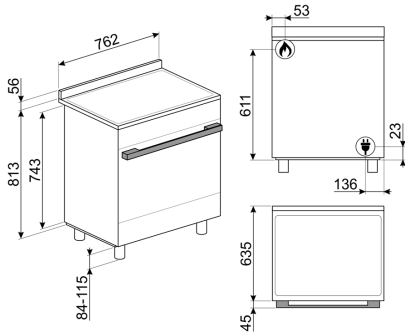

## Product installation drawing

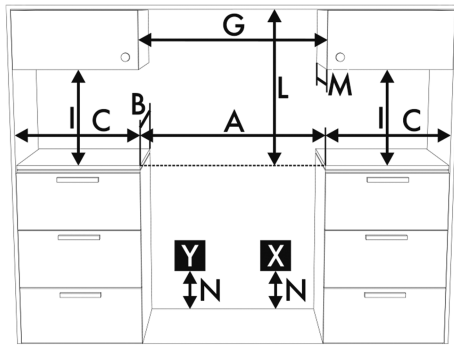

A	1220 mm	48 1/16"
B	636 mm	25"
C <sup>1</sup>	216 mm	8 1/2"
G <sup>2</sup>	1220 mm	48 1/16"
i <sup>3</sup>	457 mm	18"
L <sup>4</sup>	610 mm	24"
M <sup>5</sup>	330 mm	13"
N	178 mm	7"

## Accessories



### GT91P

Partially extractable telescopic guides suitable for 90 cm Master and Sinfonia cookers



### PALPZ

Pizza shovel with fold away handle