

# A2-81

Categorie fornuis	100x60 cm
N. of cavities with energy label	2
Cavity heat source	Elektriciteit
Type kookplaat	Gas
Type primaire oven	Thermogeventileerd
Type secundaire oven	Statisch
Reinigingssysteem primaire oven	Katalyse reiniging
EAN-code	8017709256746
Energie-efficiëntieklasse	A
Energie-efficiëntieklasse, tweede oven	B



## Design











<b>Design</b>	Speciaal	<b>Bediening</b>	Bedieningsknoppen
<b>Afwerking bedieningspaneel</b>	Inox finger friendly	<b>Bedieningsknoppen</b>	Smeg Classici
<b>Design</b>	Classici	<b>Kleur bedieningsknoppen</b>	Inox
<b>Logo</b>	Assembled st/steel	<b>Aantal bedieningsknoppen</b>	10
<b>Kleur</b>	Inox	<b>Kleur serigrafie</b>	Zwart
<b>Positie logo</b>	Strook onder de oven	<b>Display</b>	DigiScreen
<b>Afwerking</b>	Geborsteld inox	<b>Deur</b>	Met 2 horizontale stroken
<b>Upstand</b>	Ja	<b>Type glas</b>	Eclipse zwart glas
<b>Series</b>	Opera	<b>Handgreep</b>	Smeg Classici
<b>Kleur kookplaat</b>	Inox	<b>Kleur handgreep</b>	Geborsteld inox
<b>Type pottendragers</b>	Gietijzeren pottendragers	<b>Opberg ruimte</b>	Opbergvak met lade

## Programma's / Functies

Aantal kookfuncties	8
---------------------	---

## Traditionele bereidingsfuncties





 Statisch	 Geventileerd	 Circulatie (ventilator + circulaire)
 ECO	 Kleine grill	 Grote grill
 Ventilator + kleine grill	 Geventileerde onderwarmte	

## Reinigingsfuncties

Katalyse reiniging	 Vapor Clean reiniging
--------------------	---

## Programma's / Functies secundaire oven

Aantal kookfuncties 4  
 Traditionele bereidingsfuncties, 2e oven

 Statisch	 Kleine grill	 Grote grill
 Onderwarmte		

## Technische specificaties kookplaat



Totaal aantal kookzones 6

Linksvoor - Gas - SRD - 1.80 kW  
 Linksachter - Gas - 2URP (dual) - 4.20 kW  
 Middenvoor - Gas - AUX - 1.00 kW  
 Middenachter - Gas - SRD - 1.80 kW  
 Rechtsvoor - Gas - 2URP (dual) - 4.20 kW  
 Rechtsachter - Gas - RP - 3.00 kW

Type gasbranders	Standaard	Thermobeveiliging	Ja
Automatische vonkontsteking	Ja	Branderdeksels	Mat zwart geëmailleerd

## Technische specificaties primaire oven



Aantal lampen	1	Aantal ruiten ovendeur	3
Aantal ventilatoren	1	Aantal thermo-reflecterende ruiten	2
Netto volume 1e oven	61 l	Veiligheidsthermostaat	Ja
Bruto volume, oven 1	70 l	Koelsysteem	Mantelkoeling
Materiaal ovenruimte	Ever Clean emaille		

Aantal kookniveaus	4	Afmetingen bruikbare interne ovenruimte (hxbxd)	316x460x412 mm
Type ovenrekken	Metalen zijsteunen	Temperatuurregeling	Elektro-mechanisch
Type licht	Halogeen	Onderwarmte - vermogen	1200 W
Vermogen lamp	40 W	Bovenwarmte - vermogen	1000 W
Opties bereidingstijdprogrammering	Begin en eind	Grill - vermogen	1700 W
Automatische inschakeling verlichting bij openen deur	Ja	Grote vlakgrill - vermogen	2700 W
Opening deur	Neerwaarts	Circulatie - vermogen	2000 W
Uitneembare ovendeur	Ja	Grill type	Elektrisch
		Kantelbare grill	Ja

## Opties primaire oven

Timer	Ja	Minimum temperatuur	50 °C
Geluidssignaal einde kooktijd	Ja	Maximum temperatuur	250 °C

## Technische specificaties secundaire oven



Netto volume 2e oven	35 l	Aantal ruiten ovendeur	3
Bruto volume, oven 2	36 l	Aantal thermo-reflecterende ruiten	2
Materiaal ovenruimte	Ever Clean emaille	Veiligheidsthermostaat	Ja
Aantal kookniveaus	4	Koelsysteem	Mantelkoeling
Type ovenrekken	Metalen zijsteunen	Afmetingen bruikbare interne ovenruimte (hxbxd)	310x255x417 mm
Uitneembare bovenplaat	Ja	Temperatuurregeling	Elektro-mechanisch
Aantal lampen	1	Onderwarmte - vermogen	700 W
Type lamp	Gloeilamp	Bovenwarmte - vermogen	600 W
Vermogen lamp	25 W	Grill - vermogen	1300 W
Automatische inschakeling verlichting bij openen deur	Ja	Grote vlakgrill - vermogen	2050 W
Opening deur	Neerwaarts	Type grill	Elektrisch
Uitneembare ovendeur	Ja		

## Opties secundaire oven

Minimum temperatuur	50 °C	Maximum temperatuur	250 °C
---------------------	-------	---------------------	--------

## Meegeleverde accessoires primaire oven en kookplaat

Ovenrooster met stop	1	Inzetrooster	1
----------------------	---	--------------	---

Bakplaat (20 mm)	1	Katalyse-emaille wanden	3
Bakplaat (40 mm)	1		

## Meegeleverde accessoires secundaire oven

Ovenrooster met stop	1	Inzetrooster	1
Bakplaat	1		

## Elektrische aansluiting

Nominale aansluitwaarde	5300 W	Type stroomkabel	Double and Three Phase
Stroom	23 A	Frequentie	50/60 Hz
Spanning	220-240 V	Connection box	3 polig
Electric cable	Installed, Single phase	Stekker	Nee
Lengte voedingskabel	200 cm		

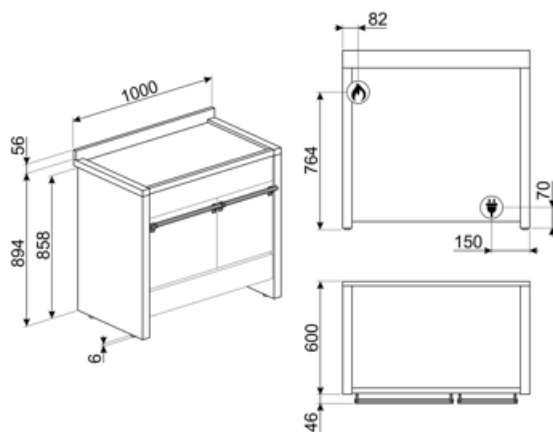

## Compatible Accessories

### AIRFRY



### BBQ

Dubbelzijdig



### BN640

Enamelled tray suitable for 45cm and 60cm ovens. Depth 540 mm. Perfect for cooking and roasting meat and fish in sauces. Also ideal for experimenting with lighter and crunchy side dishes



### GRM

Moka houder voor gaskookplaten



### GTT

Volledig uitschuifbare telescopische rails (1 niveau) voor traditionele ovens (SF-).



### KIT2A2-8

Plinth, 100 cm, only frontal, stainless steel, suitable for A2 Opera cookers



### PALPZ

Pizzapallet inox met plooibaar handvat, 315x325 mm



### SMOLD

Set van 7 siliconen vormen voor ijsjes, pralines, ijsblokjes of porties. -60°C tot 230°C.

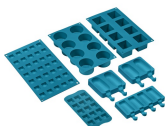

### AIRFRY2

Air fryer tray. Ideal for recreating traditional frying in the oven, but with fewer calories and less fat. It allows you to cook quickly and simply dishes such as French fries, fried vegetables and fish, ensuring perfect browning and crispiness.



### BN620-1

Enamelled tray suitable for 45 cm and 60 cm ovens. Depth 20 mm. Perfect for a wide range of savoury and sweet baking.



### BNP608T

Teflon bakplaat, 8mm diep



### GTP

Partially extractable telescopic guides (1 level), suitable for traditional ovens. Made in stainless steel, they guarantee stability and facilitate the smooth extraction of the trays.



### KIT1A2PY-81

Splashback stainless steel, 100cm, suitable for Opera A2 cookers with MF and pyro oven



### KIT3-6

Height extension kit 2 lateral sides (950mm), stainless steel, for Opera cookers A2,A3,A4 (945-965mm)































### SFLK1

Child lock



## Symbols glossary

-  Energy efficiency class A
-  Heavy duty cast iron pan stands: for maximum stability and strength.
-  Installation in column: Installation in column.
-  Triple glazed doors: Number of glazed doors.
-  Fingerprint proof stainless steel: Fingerprint proof stainless steel keeps stainless steel looking as good as new.
-  Ventilator met bovenste en onderste elementen: De elementen in combinatie met de ventilator zijn bedoeld om een meer gelijkmatige warmte te bieden, een methode die vergelijkbaar is met conventioneel koken, dus voorverwarmen is vereist. Het meest geschikt voor items die langzaam koken vereisen.
-  Base: the heat comes only from the bottom of the cavity. The fan is not active. Ideal for sweet and savory pies, cobblers and pizzas. Designed to complete cooking and make food more crunchy. This symbol in gas ovens indicates the gas burner.
-  B: Product energy rating, measured from A+++ to D / G depending on the product family.
-  Catalytic cleaning: the system ensures perfect hygiene inside the oven thanks to the three self-cleaning panels coated with a special enamel that promotes the progressive elimination of traces of grease and odors caused by cooking.
-  Air cooling system: to ensure a safe surface temperatures.
-  Ever Clean Enamel: Ever Clean enamel is applied electrostatically, corner to corner and edge to edge to prevent cracking or cracks over time. It is a particular pyrolytic enamel, resistant to acids which, in addition to being pleasantly bright, promotes greater cleaning of the oven walls, thanks to its lower porosity. It is baked at over 850 °C and slowly polymerized at a scientifically determined rate to ensure uniform depth and strength. Ever Clean enamel creates an impeccable finish both on the inside of the oven and on the trays, making the surfaces of the oven incredibly easy to maintain over time as it reduces the adhesion of fat during cooking.
-  Circogas: In gasovens verdeelt de ventilator de warmte snel en gelijkmatig over de ovenruimte, waardoor smaakoverdracht wordt vermeden bij het tegelijkertijd bereiden van een aantal verschillende gerechten. In elektrische ovens voltooit deze combinatie het koken van voedsel dat aan de oppervlakte klaar is, maar dat van binnen meer moet worden gekookt, zonder verder bruin te worden.
-  Alleen boven- en onder element: een traditionele kookmethode die het meest geschikt is voor losse items in het midden van de oven. de bovenkant van de oven zal altijd het heetst zijn. Ideaal voor gebraden vlees, fruitcake, brood etc.
-  Circulaire: De combinatie van de ventilator en het ronde element eromheen zorgt voor een hete lucht kookmethode. Dit biedt vele voordelen, waaronder geen voorverwarmen als de kooktijd meer dan 20 minuten bedraagt, geen smaakoverdracht bij het gelijktijdig bereiden van verschillende soorten voedsel, minder energie en kortere kooktijden. Geschikt voor alle soorten voedsel.

- |  |   |
|--|---|
|  De combinatie van de grill, de ventilator en onderwarmte is interessant voor het bereiden van kleine hoeveelheden.  |  De ventilator vermindert de sterke hitte van de grill en zorgt voor een uitstekende methode voor het grillen van verschillende gerechten, steaks, worst etc., door het een homogene bruining en warmteverdeling te geven zonder het voedsel uit te drogen. De bovenste twee niveaus zijn aangeraden voor deze functie. Het onderste deel van de ovenruimte kan op die manier nog gebruikt worden voor het warmhouden van voeding op hetzelfde moment. |
|  Grill: Very intense heat coming only from above from a double heating element. The fan is not active. Provides excellent grilling and gratinating results. Used at the end of cooking, it gives a uniform browning to dishes. |  Half grill: For rapid cooking and browning of foods. Best results can be obtained by using the top shelf for small items, the lower shelves for larger ones, such as chops or sausages. For half grill heat is generated only at the centre of the element, so is ideal for smaller quantities.   |
|  Side lights: Two opposing side lights increase visibility inside the oven.  |  Automatic opening: some models have Automatic opening door when the cycle is finished which is a perfect solution for handle-less kitchen units as no handle is needed. For safety reasons, the door locks automatically when the machine is in use to avoid it being opened inadvertently.   |
|  Removable roof liner: This is a perfect solution that protects the upper part of the cavity of the oven from pollution. Easy to remove for cleaning, it can be washed in the dishwasher.                                    |  The oven cavity has 4 different cooking levels.   |
|  Electronic control: Allows you to maintain temperature inside the oven with the precision 2-3 ° C. This enables to cook meals that are very sensitive to temperature changes, such as cakes, souffles, puddings.            |  Tilting grill: the tilting grill can be easily unhooked to move the heating element and clean the roof of the appliance in one simple step.   |
|  Ultra rapid burners: Powerful ultra rapid burners offer up to 5kw of power.   |  Vapor Clean: a simple cleaning function using steam to loosen deposits in the oven cavity.  |
|  The capacity indicates the amount of usable space in the oven cavity in litres.   |  The capacity indicates the amount of usable space in the oven cavity in litres.   |
|  DIGI screen display + bedieningsknoppen   |  Knobs control   |

## Benefit (TT)

---

### **Gas hob**

Gas provides permanent control of the heat source and the temperature change is immediate

Equipped with a thermocouple, the gas supply is cut off if the flame is extinguished for greater safety.

### **Catalysis**

Easy oven cleaning through the use of catalytic panels in the cavity

This permanent process allows continuous cleaning and degreasing of the three cavity walls, starting its grease oxidation phase when the oven reaches 200 °C.

### **Touch control**

Easy and intuitive timer setting with a single touch

### **Drawer storage compartment**

More space thanks to the lower drawer compartment, ideal for storing accessories or cooking utensils

### **True-convection**

The best cooking performances guaranteed by ventilated circular flow

Multiple fans and heating elements guarantee the perfect aerodynamic heat flow, allowing homogeneous and quicker cooking inside the cavity.

### **Multilevel cooking**

Several cooking levels allow maximum flexibility of use

### **Multilevel halogen light**

Internal halogen lighting on different levels guarantees excellent visibility

### **Tangential cooling**

New cooling system with tangential fan and airflow from the door to the splashback

### **Adjustable height**

Cooker top flushed with the working area thanks to adjustable feet

### **AirFry (AIRFRY optional accessory)**

Lighter and tastier food thanks to airfry basket (optional accessory)

### **Cold door**

During any function, the external door glass is cold, avoiding any risk of burns

**Pizza stone (optional accessory)**

Baking with refractory stone for soft and crispy pizza and yeast products (STONE optional accessory)

**BBQ (optional accessory)**

Barbecue cooking directly in the oven with the double-sided grill (BBQ optional accessory)

**Isothermic Cavity**

The best cooking performance at the highest energy efficiency

**Single turbine**

The oven has a fan equipped with a circular heating element allowing cooking with rotating heat