

# A90G001PX

|                                  |                        |
|----------------------------------|------------------------|
| Cooker size                      | 90x60 cm               |
| N. of cavities with energy label | 1                      |
| Cavity heat source               | Electric               |
| Hob type                         | Gas                    |
| Type of main oven                | Thermo-ventilated      |
| Cleaning system main oven        | Vapor Clean, Pyrolytic |
| EAN code                         | 8017709358303          |
| Energy efficiency class          | A+                     |

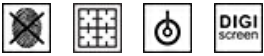

## Aesthetics



|                                |                                 |                            |                          |
|--------------------------------|---------------------------------|----------------------------|--------------------------|
| <b>Command panel finish</b>    | Finger friendly stainless steel | <b>Control knobs</b>       | Smeg Classic             |
| <b>Aesthetics</b>              | Classic                         | <b>Controls colour</b>     | Stainless steel          |
| <b>Logo</b>                    | Assembled st/steel              | <b>No. of controls</b>     | 8                        |
| <b>Colour</b>                  | Stainless steel                 | <b>Serigraphy colour</b>   | Black                    |
| <b>Logo position</b>           | Facia below the oven            | <b>Display</b>             | Touch                    |
| <b>Finishing</b>               | Brushed                         | <b>Door</b>                | With 2 horizontal strips |
| <b>Upstand</b>                 | Yes                             | <b>Glass type</b>          | dark grey                |
| <b>Series</b>                  | Opera                           | <b>Handle</b>              | Smeg Opera Classic       |
| <b>Hob colour</b>              | Stainless steel                 | <b>Handle Colour</b>       | Brushed stainless steel  |
| <b>Type of pan stands</b>      | Cast Iron                       | <b>Storage compartment</b> | Door                     |
| <b>Type of control setting</b> | Control knobs                   | <b>Feet</b>                | Silver                   |

## Programs / Functions

|                          |    |
|--------------------------|----|
| No. of cooking functions | 10 |
|--------------------------|----|

### Traditional cooking functions



Static



Fan assisted



Circulaire



Turbo (circulaire + bottom + upper + fan)



ECO



Small grill



Large grill



Fan grill (large)



Base



Fan assisted base

### Other functions



Defrost by time

### Cleaning functions



Pyrolytic



Vapor Clean

## Hob technical features

**UR**

### Total no. of cook zones 6

Front left - Gas - 2UR (dual) - 4.20 kW

Rear left - Gas - AUX - 1.00 kW

Front centre - Gas - AUX - 1.00 kW

Rear centre - Gas - Semi Rapid - 1.80 kW

Front right - Gas - Semi Rapid - 1.80 kW

Rear right - Gas - Rapid - 3.00 kW

Type of gas burners Standard

Gas safety valves Yes

Automatic electronic ignition Yes

Burner caps Matte black enamelled

## Main Oven Technical Features



No. of lights 2

Fan number 2

Net volume of the cavity 115 litres

Gross volume, 1st cavity 129 l

Total no. of door glasses 3

No. of thermo-reflective door glasses 2

Safety Thermostat Yes

|                                     |                   |   |                    |
|-------------------------------------|-------------------|---|--------------------|
| <b>Cavity material</b>              | Easy clean enamel | <b>Cooling system</b>                         | Tangential         |
| <b>Shelf positions</b>              | 5                 | <b>Door Lock During Pyrolysis</b>             | Yes                |
| <b>Type of shelves</b>              | Metal racks       | <b>Usable cavity space dimensions (HxWxD)</b> | 371x724x418 mm     |
| <b>Light type</b>                   | Halogen           | <b>Temperature control</b>                    | Electro-mechanical |
| <b>Light power</b>                  | 40 W              | <b>Lower heating element power</b>            | 1700 W             |
| <b>Cooking time setting</b>         | Start and Stop    | <b>Upper heating element - Power</b>          | 1200 W             |
| <b>Light when oven door is open</b> | Yes               | <b>Grill element</b>                          | 1700 W             |
| <b>Door opening</b>                 | Flap down         | <b>Large grill - Power</b>                    | 2900 W             |
| <b>Removable door</b>               | Yes               | <b>Circular heating element - Power</b>       | 2 x 2000 W         |
| <b>Full glass inner door</b>        | Yes               | <b>Grill type</b>                             | Electric           |
| <b>Removable inner door</b>         | Yes               | <b>Soft Close system</b>                      | Yes                |

## Options Main Oven

|                                      |     |                            |        |
|--------------------------------------|-----|----------------------------|--------|
| <b>Timer</b>                         | Yes | <b>Minimum Temperature</b> | 50 °C  |
| <b>End of cooking acoustic alarm</b> | Yes | <b>Maximum temperature</b> | 260 °C |

## Accessories included for Main Oven & Hob



|   |   |   |   |
|---|---|---|---|
| <b>Cast iron wok support</b>                | 1 | <b>Grill mesh</b>                                 | 1 |
| <b>Chrome shelf with back and side stop</b> | 2 | <b>Telescopic Guide rails, partial Extraction</b> | 1 |
| <b>20mm deep tray</b>                       | 1 | <b>Meat Probe</b>                                 | 1 |
| <b>40mm deep tray</b>                       | 1 |   |   |

## Electrical Connection

|                       |           |   |                             |
|-----------------------|-----------|---|-----------------------------|
| <b>Max Power Draw</b> | 4200 W    | <b>Additional connection modalities</b> | Yes, Double and Three Phase |
| <b>Current</b>        | 19 A      | <b>Frequency</b>                        | 50/60 Hz                    |
| <b>Voltage</b>        | 220-240 V | <b>Terminal block</b>                   | 3 poles                     |
| <b>Cable testing</b>  | Yes       | <b>Plug</b>                             | No                          |

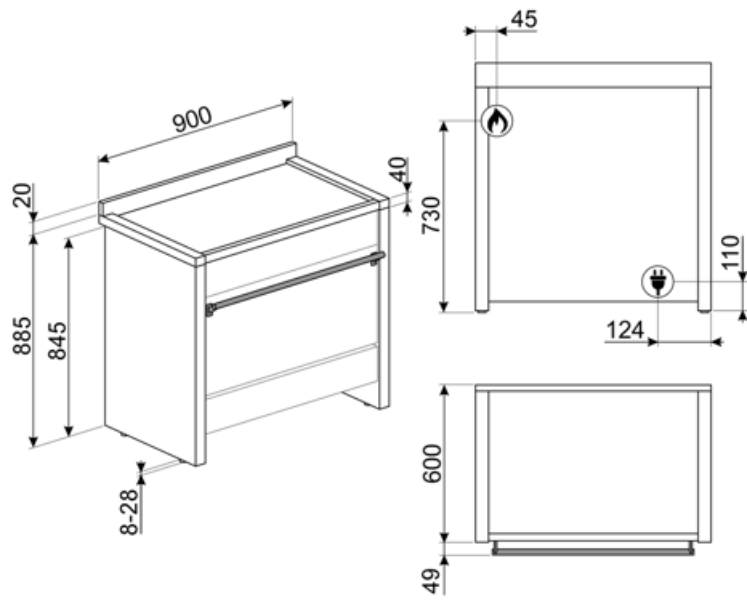

## Compatible Accessories

### AIRFRY9

Air fryer rack AIRFRY . Ideal for recreating traditional frying in the oven, but with fewer calories and less fat. It allows you to cook quickly and simply dishes such as French fries, fried vegetables and fish, ensuring perfect browning and crispiness.



### BN920

Enamelled tray 90cm cavity, 20mm deep



### GTP

\*\*Partially extractable telescopic guides (1 level)\*\* Extraction: 300 mm Material: Stainless steel AISI 430 polished



### SFLK1

Child lock



### BBQ9

teflon-coated aluminum grid for 90 cm cavity



### BN940

Enamelled tray 90 cm, 40 mm deep



### GTT

\*\*Totally extractable telescopic guides (1 level)\*\* Extraction: 433 mm Material: Stainless steel AISI 430 polished







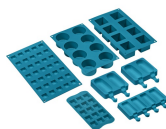

























### SMOLD

Set of 7 silicone moulds for ice creams, ice lollies, pralines, ice cubes or to portion food. Usable from -60°C to +230°C



## Symbols glossary

|  |   |
|--|---|
|  <p>A+: Energy efficiency class A+ helps to save up to 10% energy compared to class A. Maximum performance with minimum consumption is guaranteed.</p>   |  <p>Heavy duty cast iron pan stands: for maximum stability and strength.</p>   |
|  <p>Installation in column: Installation in column</p>   |  <p>Air cooling system: to ensure a safe surface temperatures.</p>   |
|  <p>Defrost by time: with this function the time of thawing of foods are determined automatically.</p>   |  <p>Triple glazed doors: Number of glazed doors.</p>   |
|  <p>Enamel interior: The enamel interior of all Smeg ovens have a special antacid lining which helps keep the interior clean by reducing the amount of cooking grease adhering to it.</p>  |  <p>Fingerprint proof stainless steel: Fingerprint proof stainless steel keeps stainless steel looking as good as new.</p>   |
|  <p>Fan assisted base: the mix of fan and lower heating element alone allows to finish cooking foods already cooked on the surface but not internally more quickly. This system is recommended to finish cooking foods that are already well cooked on the surface, but not internally, which therefore require a moderate higher heat. Ideal for any type of food.</p>  |  <p>Fan with upper and lower elements: The elements combined with the fan aim to provide more uniform heat, a similar method to conventional cooking, so pre-heat is required. Most suitable for items requiring slow cooking methods.</p>   |
|  <p>Upper and lower element only: a traditional cooking method best suited for single items located in the centre of the oven. the top pf the oven will always be hottest. Ideal for roast, fruit cakes, bread etc.</p>  |  <p>Lower heating element only: This function is ideal for foods that require extra base temperature without browning, e.g. pastry dishes, pizza. Also suitable for slow cooking of stews and casseroles.</p>  |
|  <p>Circulaire: The combination of the fan and circular element around it gives a hot air cooking method. This provides many benefits including no preheat if cook time is more than 20 minutes, no flavour transfer when cooking different foods at the same time, less energy, and shorter cook times. Good for all types of food.</p>   |  <p>ECO: The combination of the grill, fan and lower element is particularly suitable for cooking small quantities of food.</p>  |
|  <p>Grill element: Using of grill gives excellent results when cooking meat of medium and small portions, especially when combined with a rotisserie (where possible). Also ideal for cooking sausages and bacon.</p>  |  <p>Half grill: For rapid cooking and browning of foods. Best results can be obtained by using the top shelf for small items, the lower shelves for larger ones, such as chops or sausages. For half grill heat is generated only at the centre of the element, so is ideal for smaller quantities.</p>  |
|  <p>Fan with grill element: The fan reduces the fierce heat from the grill, providing an excellent method of grilling various foods, chops, steaks, sausages etc. giving even browning and heat distribution, without drying out the food. The top two levels recommended for use, and the lower part of the oven can be used to keep items warm at the same time, an excellent facility when cooking a grilled breakfast. Half grill (centre portion only) is ideal for small quantities of food.</p> |  <p>Circulaire with upper and lower elements: The use of the fan with both elements allows food to be cooked quickly and effectively, ideal for large joints that require thorough cooking. It offers a similar result to rotisserie, moving the heat around the food, instead of moving the food itself, enabling any size or shape to be cooked.</p> |

- 
- |  |  |
|--|--|
|  <p>All glass inner door: All glass inner door, a single flat surface which is simple to keep clean.</p>   |  <p>The inner door glass: can be removed with a few quick movements for cleaning.</p>   |
|  <p>Side lights: Two opposing side lights increase visibility inside the oven.</p>   |  <p>Automatic opening: some models have Automatic opening door when the cycle is finished which is a perfect solution for handle-less kitchen units as no handle is needed. For safety reasons, the door locks automatically when the machine is in use to avoid it being opened inadvertently.</p> |
|  <p>Pyrolytic: Pyrolytic cleaning cycles can be selected as necessary to automatically clean the oven interior.</p>                                      |  <p>The oven cavity has 5 different cooking levels.</p>   |
|  <p>Soft close: all models are equipped with advanced function of smooth closing of the door, which allows the device to close smoothly and quietly.</p> |  <p>Telescopic rails: allow you to pull out the dish and check it without having to remove it from the oven entirely.</p>   |
|  <p>Ultra rapid burners: Powerful ultra rapid burners offer up to 5kw of power.</p>  |  <p>Vapor Clean: a simple cleaning function using steam to loosen deposits in the oven cavity.</p>  |
|  <p>The capacity indicates the amount of usable space in the oven cavity in litres.</p>   |  <p>The touch timer display or DigiScreen guarantees simple functionality. They display the time, set programmed cooking and the minute minder timer.</p>  |
|  <p>Knobs control</p>  |  |