

# ALFA420H-2



<b>Família</b>	Fornos
<b>Subfamília</b>	Convection oven 4 trays EN 600x400 mm, GN 1/1 (min. H 20 mm)
<b>Tipo de energia</b>	Elétrico
<b>Tipo de forno</b>	Forno de convecção com humedificação
<b>Controlo do forno</b>	Controlo mecânico da temperatura
<b>Capacidade de tabuleiro</b>	4 tabuleiros EN 600x400 mm, GN1/1 (mín. H 20 mm)
<b>Fonte de energia</b>	400 V 3N~ / 10 A / 6,9 kW / 50 Hz
<b>Outras ligações eléctricas</b>	230 V~ / 30 A / 6,9 kW / 50 Hz
<b>Memória de programas</b>	Não disponível
<b>Geração de humidade</b>	Direto na cavidade
<b>Pés reguláveis em altura</b>	Sim
<b>Dimensões do produto (LxPxA)</b>	798x747x563 mm
<b>Profundidade máxima com a porta aberta</b>	1145 mm



## Mercado

<b>Indústrias</b>	Bares, Cafés e Pubs; Hotelaria; Restaurantes; Padarias / Pastelarias; Talhos; Catering; Estabelecimentos de Cuidados; Indústrias Alimentares; Supermercados / Comércio de alimentos
-------------------	--

## Design

<b>Porta com tiras em aço inox</b>	Sim	<b>Painel frontal Design</b>	Sim
<b>Cor</b>	Aço inox		Alfa

## Comandos

<b>Temporizador</b>	1-99 min + Sem fim
---------------------	--------------------

## Opções

<b>Exaustor compatível</b>	K4610X (com kit de conexão KITPO45)
----------------------------	-------------------------------------

## ESPECIFICAÇÕES TÉCNICAS

<b>Material do forno</b>	Aço Inox / Vidro / Plástico	<b>Níveis de humificação</b>	Manual
<b>Dimensões da cavidade (LxPxA)</b>	672x437x340 mm	<b>Posição de exaustão</b>	Traseira
<b>Volume bruto</b>	115,6 lt	<b>Tipo de temporizador</b>	Elétrico
<b>Volume útil</b>	104,2 lt	<b>Temperaturas</b>	50-270°C
<b>Volume útil interno</b>	75 lt	<b>Aviso de final de cozedura</b>	Sim
<b>Material da cavidade</b>	Aço inox	<b>Luz indicadora (laranja) de temperatura atingida</b>	Sim
<b>Níveis de tabuleiros</b>	4	<b>Luz indicadora (verde) de tempo atingido</b>	Sim
<b>Suporte dos tabuleiros</b>	Cromado	<b>Interruptor de segurança com porta aberta</b>	Sim
<b>Distância entre tabuleiros</b>	77 mm	<b>Reset de segurança do termostato</b>	Sim
<b>Material da porta</b>	Vidro duplo	<b>Deflector removível</b>	Sim
<b>Abertura da porta</b>	Basculante	<b>Iluminação</b>	2 lâmpadas de halogéneo
<b>Tipo de puxador</b>	Fixo	<b>Potência das lâmpadas</b>	40 W
<b>Vidro</b>	Abre com clip	<b>Tubo de carga de água</b>	Sim
<b>Tipologia da ventoinha</b>	2 com rotação reversível temporizada	<b>Pressão da entrada de água</b>	50-500 kPa (min-max)
<b>Potência da ventoinha</b>	180W	<b>Comprimento do cabo de alimentação</b>	170 cm
<b>RPM da ventoinha</b>	Velocidade única	<b>Painel traseiro</b>	Porta galvanizada
<b>RPM standard da ventoinha</b>	2850 rpm	<b>Proteção IPX</b>	IPX3

## Dados de logística

<b>Dimensões do produto embalado (LxPxA)</b>	960x845x640 mm	<b>Peso líquido (kg)</b>	58.500 kg
<b>Código EAN</b>	8017709270117	<b>Peso bruto (kg)</b>	70.400 kg

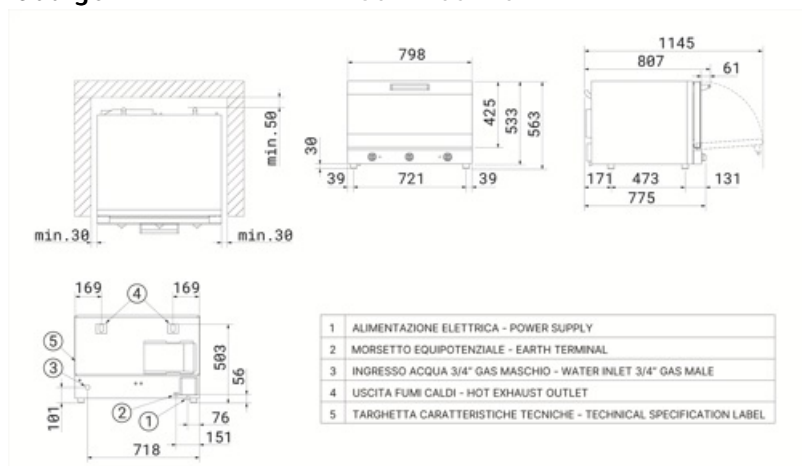

## Acessórios Compatíveis

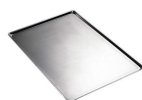

**3743**



**3751**

Kit of 4 flat perforated aluminium tray  
EN 600×400 mm



**3805**

Kit of 4 chrome-plated wire grids EN  
600×400 mm

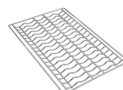

**3810**



**3927**

Air flow reducer kit for ovens ALFA410,  
420, 625, 1035

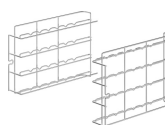

**RGN11-420-2**

Support rack for GN 1/1 flat trays,  
suitable for ALFA420/425/410 models



**RUTVL**

Set of 4 wheels, fits all professional oven  
tables



**SVRPP420-625**

Connection kit for stacking two 4ltray  
EN 600×400 ovens with hood  
K4610X, one 4ltray EN 600×400 oven  
with one 6ltray EN 600×400 oven  
with hood K4610X, or two 6ltray EN  
600×400 ovens without hood



**T11TH20**

GN1/1 non-stick tray, 20 mm height



**T11TH40**

GN1/1 non-stick tray, 40 mm height



**T11XH20**

Aluminium GN1/1 tray, 20 mm height



**T11XH65**

GN1/1 aluminium tray, 65 mm height

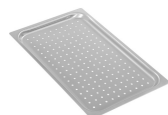

**TF11XH2**

GN 1/1 perforated aluminium tray, 20  
mm height

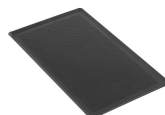

**TMF11TH2**

GN 1/1 non-sticking microperforated  
tray, 20 mm height



**TVL425**

16-level tray holder rack for  
ALFA410/ALFA420/425 and ALFA625  
ovens dim. (WxDxH) 800x800x900 mm  
(height with kit RUTVL: 998 mm)



**TVL425D**

4-level tray holder rack for  
ALFA410/ALFA420/ALFA425  
(stacked) or ALFA1035 ovens, dim.  
(WxDxH) 800x800x504 mm (height  
with kit RUTVL: 602 mm)

## Symbols glossary

---



Elétrico: a fonte de energia do forno é a eletricidade.



Fan forced heating



Fan forced heating with humidity injection

## Benefit (TT)

---

### **Mechanical control panel**

Ease of use and effortless control of the essential cooking parameters

The control panel, equipped with practical knobs, allows for simple, intuitive, and effortless management of the main functions. Using the buttons, you can adjust the cooking time, temperature, and, in selected models, the level of humidification. By turning the knob to position 1, steam will be delivered until it is released.

In multifunction ovens with a mechanical control panel, there is also a dedicated button for selecting different oven functions based on the desired cooking mode.

### **Clip-open**

Easily accessible glass for effortless maintenance and cleaning

The glass panels are designed to be easily accessible and inspectable, ensuring great convenience during cleaning and maintenance operations. This feature significantly simplifies the process, making it quick and efficient, while ensuring that every intervention can be carried out with maximum comfort and complete safety.

### **Humidity management**

Impeccable cooking thanks to precise humidity control

Thanks to the effective management of small amounts of humidity, perfect browning can be achieved while maintaining the product's softness and promoting the development of its internal structure. Different humidity levels can be set, which determine the frequency of activation cycles. Each cycle consists of two seconds of water vapour spraying inside the cooking chamber, followed by a 15-second pause.