

ALFA425EHDS

Product Family	Ovens
Subfamily	Convection oven 4 trays EN 600x400 mm or GN1/1
Oven type	Fan with humidification
Oven controls	Electronic
Tray capacity	4 trays 600x400 mm - GN1/1
Default power supply	400 V 3N~ / 10 A / 6,9 kW / 50-60 Hz
Other electrical connections	230 V~ / 30 A / 6.9 kW / 50-60 Hz
Steam technology	Direct
App for recipe development and upload	Not available
Maximum depth with open door	1145 mm
Adjustable feet	Yes
Net weight (kg)	61,000 kg
Product dimensions WxDxH	798x747x563 mm
EAN code	8017709291150



Target

Potential users	Bars/Cafes; Hotels; Restaurants/Catering; Bakery/Pastry making; Industrial pastry & bakery test kitchen; Butcher's shops; QSR	Suggested for	Bars/Cafes
------------------------	---	----------------------	------------

Aesthetics

Colour	Stainless steel	Digital display colour	White
Door with stainless steel strip	Yes	Front panel	Yes
Display type	Yes	Logo	Smeg printed

Controls

Adjustable timer	1 min - 99hrs + continuous	Adjustable chimney	On/off
Cooking steps	9	HACCP data	Scheduled start H/12

Options

Condense hood	K4610X
----------------------	--------

Construction

Oven material	Stainless steel/glass/plastics	Steam assisted levels	5 + manual
Cavity dimensions (WxDxH)	672x437x340mm	Exhaust exit	Back
Gross volume	670x560x420mm	Cooling system	Yes
Net volume	670x560x420mm	Time adjustment	Electronic timer
Internal net volume	199,1 lt	Temperature range	50-280°C
Cavity material	Stainless steel	End of cooking alarm	Yes
No. of shelves	4	Heating element interruption with open door	Yes
Tray support frame	Chrome	Manual safety thermostat reset	Yes
Distance between shelves	77 mm	Core probe cooking with Δt	Yes
Door construction	Yes	Removable deflector	Yes
Door opening	Lateral	No. of lights	2 LED lights
Handle type	New ergonomics	Light power	40 W
Inner glass	Removable	USB port	Yes
Fan type and number	2 contrarotating fans with time direction reversal	Water connection	Yes
Fan speed	Double speed	Power cable length	170 cm
Max motor speed (rpm)	2	Back panel	Galvanized
Low motor speed (rpm)	2	IPX protection	Scheduled start H/12
Humidification system on each fan	Yes		

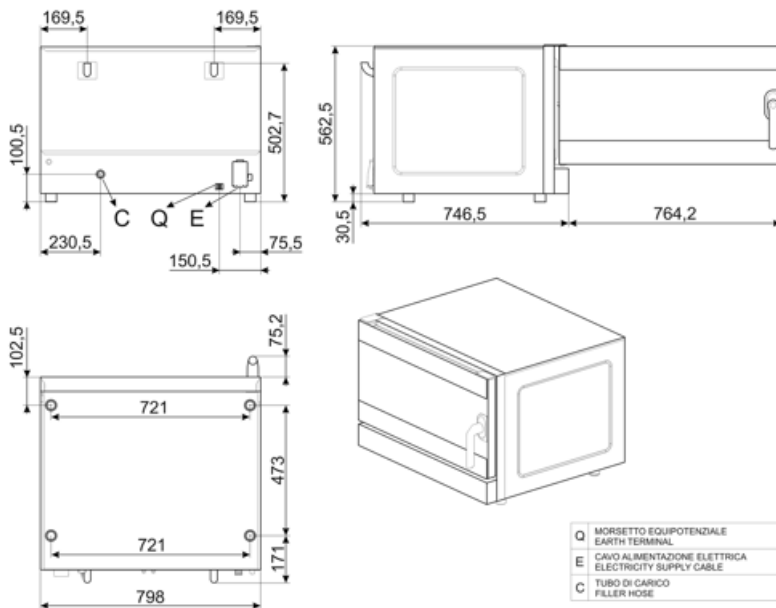

Not included accessories



3743
Flat aluminium tray



3751
Flat perforated aluminium tray



3805
Flat chrome-plated wire grid



3810
Corrugated grid for baguettes



3927
Air flow reducer kit



RGN11-420-2
Support kit for grids or flat trays
GN1/1 suitable for ALFA420/425/410
models



SVRPP420-625
Connector kit for two stacked
ALFA420+420 or ALFA420+625 models
and hood

SVRPP625
Conjunction kit for 2 ovens series
625/420 and hood



T11TH20
2cm height GN1/1 non-stick tray for
Galileo professional



T11TH40
4cm height GN1/1 non-stick tray for
Galileo professional



T11XH20
2cm height aluminium GN1/1 tray for
Galileo professional



T11XH65
6,5cm height aluminium GN1/1 tray
for Galileo professional

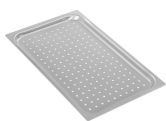

TF11XH2
Perforated aluminium GN1/1 tray for
Galileo professional

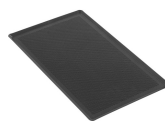

TMF11TH2
GN 1/1 non-sticking microperforated
tray

Symbols glossary



Core probe



Fan forced



Fan with humidification



Double speed fan