

ALFA43XE1HDS

Familie	Professional ovens
Subfamily	Multifunction oven 4 trays 435x320 mm
Oven type	Multifunctioneel
Ovenbediening	Elektronisch
Laad capaciteit	4 trays 435x320 mm or GN2/3
Electrische aansluiting	230 V~ / 13 A / 3,0 kW / 50 Hz
Stoom technologie	Direct
Program storage with application	Not available
Diepte open deur	1178 mm
verstelbare poten	Ja
Netto gewicht	38,100 kg
Product dimensions WxDxH	608x600x537 mm
EAN code	8017709294366



Target

Solutions	Coffee shops/Wine bars; Hotels; Restaurants/Pubs; Bakery/Pastry making; Frozen bakery industry; Food retail; QSR
------------------	--

Design

Kleur	Roestvrij staal	Led kleur	Wit
Deur met roestvrijstalen delen	Ja	Front paneel met relief Logo	Ja Smeg gedrukt
Digitaal TFT display	LCD		

Bediening

Veranderbare programma's	99	Timer optie	Ja
Programmeerbare minuten	from 1 minute to 99 hours + endless	Bakken in fases	Ja
Bakken in fases	3 + pre-heating		

Opties

Combinable hood	K43X
------------------------	------

Meegeleverde accessoires

Aluminium bakplaat
3820

kit of 4 pieces

Water connection pipe Ja

Elektrische aansluiting

Stekker (F;E) Schuko

Construction

Materiaal bakruimte	Ever Clean emaille	Vochtigheidsniveaus	5 + manual
Afmetingen bakruimte (BxDxH)	460x360x425 mm	Water aansluiting	Back
Afmetingen bakruimte (BxDxH)	54,5 lt	Tijd instellen	Electrical
Materiaal bakruimte	Ever Clean emaille	Temperatuur bereik	30-270°C
Aantal kookniveau's	4	Einde baktijd alarm	Ja
Frame bakplaat geleiders	Verchromd	Verwarmingselement schakelt uit bij open deur	Ja
Afstand tussen bakkiveaus	80 mm	Handmatige reset van thermostaat	Ja
Goed geïsoleerde deur met compleet te openen binnenruit	Ja	Water aansluiting	Ja
Deur openen	Tilting	Verlichting	1 Halogen lamp
Type handvat	Smeg	Vermogen lamp	40 W
Binnenruit	Openable with clip	USB port	Ja
Materiaal bakruimte	80W	Water aansluiting	Ja
Materiaal bakruimte	Dual speed	Lengte voedingskabel	115 cm
Materiaal bakruimte	2700 rpm	Achterwand	Verzinkt
Materiaal bakruimte	2100 rpm	Timer optie	IPX3
Bevochtiging op elke ventilator	Ja		

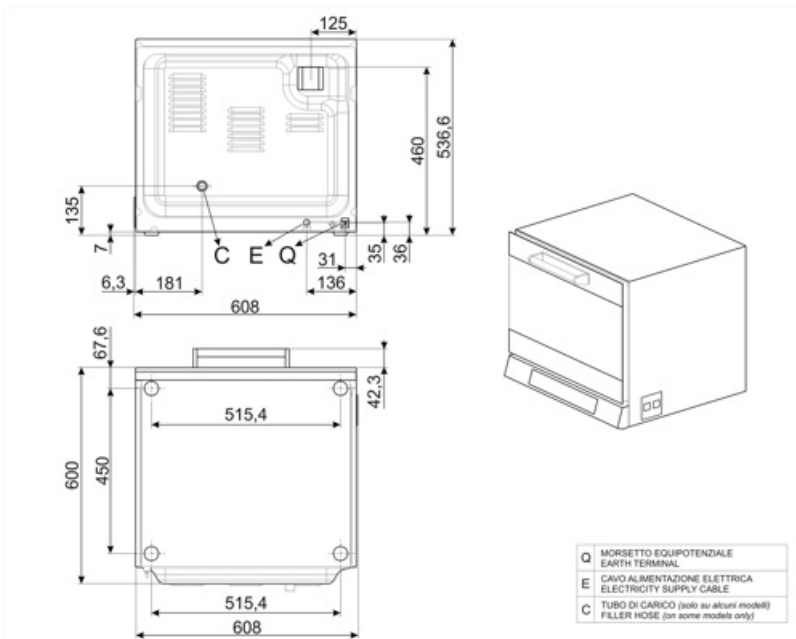

Compatibile Accessoire



3755
Flat perforated aluminium tray (4pcs)

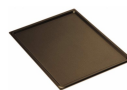

3780
Flat non-stick trays (4pcs)



3820
Flat aluminised steel tray (4pcs)



3900
Flat chrome-plated wire grid (4pcs)













3926
Air flow reducer kit for ALFA43 ovens



4730
External tank kit 5 lt.

Symbols glossary

	Double speed fan		Fan with lower element
	Fan forced heating		Fan forced heating with humidity injection
	Fan assisted upper grill		Lower heating element
	Upper and lower element heating with fan		Fan grill heating
	Large grill heating element		Static heating with upper and lower elements