

ALFA625H-2

Product Family	Ovens
Subfamily	Convection oven 6 trays en 600x400 mm or GN1/1
Oven type	Fan with humidification
Oven controls	Mechanical
Tray capacity	6 trays 600x400 mm - GN1/1
Default power supply	400 V 3N~ / 16 A / 10,5 kW / 50-60 Hz
Steam technology	Direct
App for recipe development and upload	Not available
Maximum depth with open door	1521 mm
Adjustable feet	Yes
Net weight (kg)	76,000 kg
Product dimensions WxDxH	798x757x793 mm
EAN code	8017709270193



Target

Potential users	Bars/Cafes; Hotels; Restaurants/Catering; Bakery/Pastry making; Industrial pastry & bakery test kitchen; Butcher's shops	Suggested for	Bars/Cafes
------------------------	--	----------------------	------------

Aesthetics

Colour	Stainless steel	Front panel	Yes
Door with stainless steel strip	Yes	Logo	Smeg printed

Controls

Adjustable timer	1-60 minutes + continuous	Adjustable chimney	Manual
-------------------------	---------------------------	---------------------------	--------

Options

Right hand hinge	ALFA625HR-2	Condense hood	K4610X
Right hand hinge	ALFA1035EHDSR		

Construction

Oven material	Stainless steel/glass/plastics	Humidification system on each fan	Yes
----------------------	--------------------------------	--	-----

Cavity dimensions (WxDxH)	672x437x546mm	Steam assisted levels	Manual
Gross volume	460x360x425mm	Exhaust exit	Back
Net volume	460x360x425mm	Time adjustment	Electromechanical timer
Internal net volume	127,3 lt	Temperature range	50-270°C
Cavity material	Stainless steel	End of cooking alarm	Yes
No. of shelves	6	Orange light indicator when t° achieved	Yes
Tray support frame	Chrome	Green light indicator when time achieved	Yes
Distance between shelves	77 mm	Heating element interruption with open door	Yes
Door construction	Yes	Manual safety thermostat reset	Yes
Door opening	Lateral	Removable deflector	Yes
Handle type	New ergonomics	No. of lights	2 LED lights
Inner glass	Openable	Light power	40 W
Fan type and number	2 contrarotating fans with time direction reversal	Water connection	Yes
Fan motor power	180W	Power cable length	170 cm
Fan speed	Single speed	Back panel	Galvanized
Max motor speed (rpm)	2	IPX protection	Scheduled start H/12

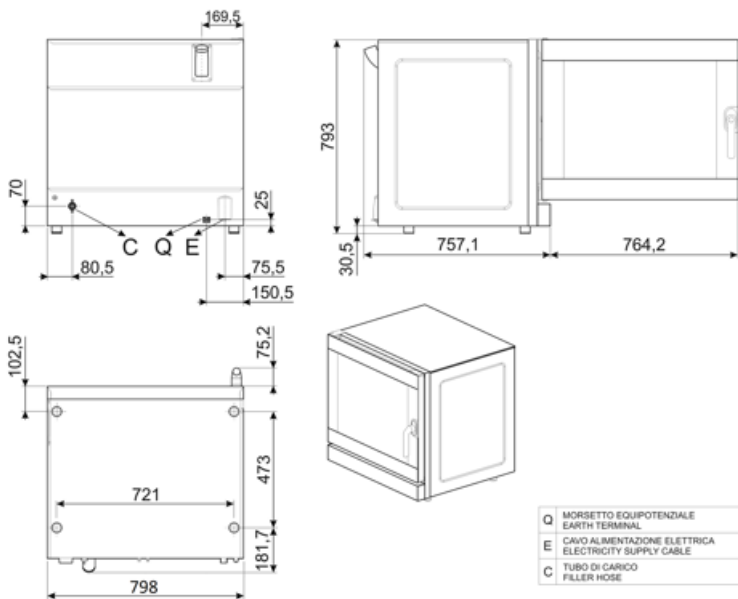

Not included accessories



3743
Flat aluminium tray



3751
Flat perforated aluminium tray



3805
Flat chrome-plated wire grid



3810
Corrugated grid for baguettes



3927
Air flow reducer kit



RGN11-625-2



SVRPP420-625
Connector kit for two stacked
ALFA420+420 or ALFA420+625 models
and hood



T11TH20
2cm height GN1/1 non-stick tray for
Galileo professional



T11TH40
4cm height GN1/1 non-stick tray for
Galileo professional



T11XH20
2cm height aluminium GN1/1 tray for
Galileo professional



T11XH65
6,5cm height aluminium GN1/1 tray for
Galileo professional

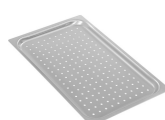

TF11XH2
Perforated aluminium GN1/1 tray for
Galileo professional

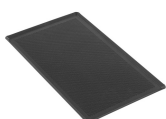

TMF11TH2
GN 1/1 non-sticking microperforated
tray

Symbols glossary



Fan forced



Fan with humidification