

ALFA625HR-2



Família	Fornos
Subfamília	Forno de convecção
Tipo de energia	Elétrico
Tipo de forno	Forno de convecção com humidificação
Controlo do forno	Controlo mecânico da temperatura
Capacidade de tabuleiro	6 tabuleiros EN 600x400 mm, GN1/1 (mín. H 20 mm)
Fonte de energia	400 V 3N~ / 16 A / 10,5 kW / 50 Hz
Outras ligações eléctricas	230 V 3~ / 16 A / 10,5 kW / 50 Hz
Memória de programas	Não disponível
Geração de humidade	Direto na cavidade
Pés reguláveis em altura	Sim
Dimensões do produto (LxPxA)	798x757x793 mm
Profundidade máxima com a porta aberta	1521 mm



Mercado

Indústrias	Bares, Cafés e Pubs; Hotelaria; Restaurantes; Padarias / Pastelarias; Talhos; Catering; Estabelecimentos de Cuidados; Indústrias Alimentares; Supermercados / Comércio de alimentos	Indicado para	Padaria / Pastelaria
-------------------	--	----------------------	----------------------

Design

Porta com tiras em aço inox	Sim	Painel frontal Design	Sim
Cor	Aço inox		Alfa

Comandos

Temporizador	1-99 min + Sem fim	Regulação da chaminé	Manual
---------------------	--------------------	-----------------------------	--------

Opções

Dobradiça à direita	Sim	Exaustor compatível	K4610X (com kit de conexão KITPO45)
----------------------------	-----	----------------------------	-------------------------------------

ESPECIFICAÇÕES TÉCNICAS

Material do forno	Aço Inox / Vidro / Plástico	Níveis de humificação	Manual
Dimensões da cavidade (LxPxA)	672x437x546 mm	Posição de exaustão	Traseira
Volume bruto	184,8 lt	Tipo de temporizador	Elétrico
Volume útil	165,6 lt	Temperaturas	50-270°C
Volume útil interno	127,3 lt	Aviso de final de cozedura	Sim
Material da cavidade	Aço inox	Luz indicadora (laranja) de temperatura atingida	Sim
Níveis de tabuleiros	6	Luz indicadora (verde) de tempo atingido	Sim
Suporte dos tabuleiros	Cromado	Interruptor de segurança com porta aberta	Sim
Distância entre tabuleiros	77 mm GN1/1 - EN 600X400	Reset de segurança do termostato	Sim
Material da porta	Vidro duplo	Deflector removível	Sim
Abertura da porta	Lateral - dobradiça à direita	Iluminação	2 lâmpadas de halogéneo
Tipo de puxador	Rotativo	Potência das lâmpadas	40 W
Vidro	Abre com dobradiça	Tubo de carga de água	Sim
Tipologia da ventoinha	2 com rotação reversível temporizada	Pressão da entrada de água	50-500 kPa (min-max)
Potência da ventoinha	180W	Comprimento do cabo de alimentação	170 cm
RPM da ventoinha	Velocidade única	Painel traseiro	Porta galvanizada
RPM standard da ventoinha	2850 rpm	Proteção IPX	IPX3
Injeção de água em cada ventoinha	Sim		

Dados de logística

Dimensões do produto embalado (LxPxA)	960x890x820 mm	Peso líquido (kg)	73,900 kg
Código EAN	8017709290054	Peso bruto (kg)	93,000 kg

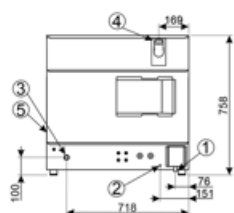
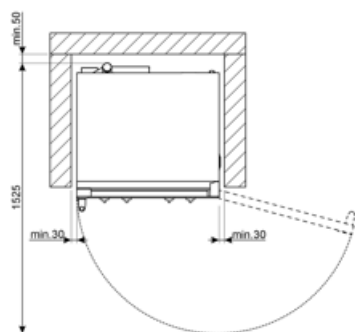
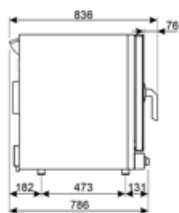
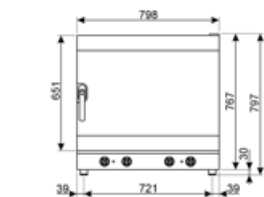

- | | |
|---|--|
| 1 | ALIMENTAZIONE ELETTRICA - POWER SUPPLY |
| 2 | MORSETTO EQUIPOTENZIALE - EARTH TERMINAL |
| 3 | INGRESSO ACQUA 3/4" GAS MASCHIO - WATER INLET 3/4" GAS MALE |
| 4 | USCITA FUMI CALDI - HOT EXHAUST OUTLET |
| 5 | TARGHETTA CARATTERISTICHE TECNICHE - TECHNICAL SPECIFICATION LABEL |

Acessórios Compatíveis



3743



3751

Kit of 4 flat perforated aluminium tray EN 600×400 mm



3805

Kit of 4 chrome-plated wire grids EN 600×400 mm

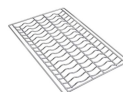

3810



3927

Air flow reducer kit for ovens ALFA410, 420, 625, 1035

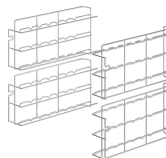

RGN11-625-2

Support rack for GN 1/1 flat trays, suitable for ALFA625 models



RUTVL

Set of 4 wheels, fits all professional oven tables



SVRPP420-625

Connection kit for stacking two 4ltray EN 600×400 ovens with hood K4610X, one 4ltray EN 600×400 oven with one 6ltray EN 600×400 oven with hood K4610X, or two 6ltray EN 600×400 ovens without hood



T11TH20

GN1/1 non-stick tray, 20 mm height



T11TH40

GN1/1 non-stick tray, 40 mm height



T11XH20

Aluminium GN1/1 tray, 20 mm height



T11XH65

GN1/1 aluminium tray, 65 mm height

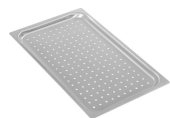

TF11XH2

GN 1/1 perforated aluminium tray, 20 mm height

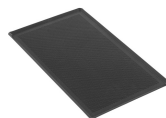

TMF11TH2

GN 1/1 non-sticking microperforated tray, 20 mm height



TVL425

16-level tray holder rack for ALFA410/ALFA420/425 and ALFA625 ovens dim. (WxDxH) 800x800x900 mm (height with kit RUTVL: 998 mm)



TVL425D

4-level tray holder rack for ALFA410/ALFA420/ALFA425 (stacked) or ALFA1035 ovens, dim. (WxDxH) 800x800x504 mm (height with kit RUTVL: 602 mm)



TVL625D

Stand for ALFA625 stacked ovens, dim.
(WxdxH) 800x800x300 mm

Symbols glossary



Elétrico: a fonte de energia do forno é a eletricidade.



Fan forced heating



Fan forced heating with humidity injection

Benefit (TT)

Mechanical control panel

Ease of use and effortless control of the essential cooking parameters

The control panel, equipped with practical knobs, allows for simple, intuitive, and effortless management of the main functions. Using the buttons, you can adjust the cooking time, temperature, and, in selected models, the level of humidification. By turning the knob to position 1, steam will be delivered until it is released.

In multifunction ovens with a mechanical control panel, there is also a dedicated button for selecting different oven functions based on the desired cooking mode.

Hinged opening

Easily accessible glass for effortless maintenance and cleaning

The glass panels are designed to be easily accessible and inspectable, ensuring great convenience during cleaning and maintenance operations. This feature significantly simplifies the process, making it quick and efficient, while ensuring that every intervention can be carried out with maximum comfort and complete safety.

Humidity management

Impeccable cooking thanks to precise humidity control

Thanks to the effective management of small amounts of humidity, perfect browning can be achieved while maintaining the product's softness and promoting the development of its internal structure. Different humidity levels can be set, which determine the frequency of activation cycles. Each cycle consists of two seconds of water vapour spraying inside the cooking chamber, followed by a 15-second pause.