



B95IMAN9

| | |
|----------------------------------|-----------------------|
| Categorie fornuis | 90x60 cm |
| N. of cavities with energy label | 1 |
| Cavity heat source | Elektriciteit |
| Type kookplaat | Inductie |
| Type primaire oven | Thermogeventileerd |
| Reinigingssysteem primaire oven | Vapor Clean reiniging |
| EAN-code | 8017709302962 |
| Energie-efficiëntieklasse | A |



Design

| | | | |
|--|---|---------------------------------|---------------------------|
|  |  | | |
| Design | Speciaal | Kleur bedieningsknoppen | Zwart |
| Afwerking bedieningspaneel | Gekleurd plaatstaal | Aantal bedieningsknoppen | 7 |
| Design | Mixed | Kleur serigrafie | Zilver |
| Logo | Assembled st/steel | Display | DigiScreen |
| Kleur | Antraciet | Deur | Met 2 horizontale stroken |
| Positie logo | Strook onder de oven | Type glas | Eclipse zwart glas |
| Series | Master | Handgreep | Rechthoekig |
| Kleur kookplaat | Antraciet | Kleur handgreep | Antraciet en mat zwart |
| Bediening | Bedieningsknoppen | Opbergruimte | Opbergvak met klep |
| Bedieningsknoppen | Smeg Master Pro Soft Touch | | |

Programma's / Functies

| | |
|---------------------|---|
| Aantal kookfuncties | 9 |
|---------------------|---|

Traditionele bereidingsfuncties

| | | |
|-------------|---------------------------|--------------------------------------|
| Statisch | Geventileerd | Circulatie (ventilator + circulaire) |
| ECO | Grote grill | Ventilator + grote grill |
| Onderwarmte | Geventileerde onderwarmte | |

Overige functies

| |
|-------------------|
| Ontdooien op tijd |
|-------------------|

Reinigingsfuncties

| |
|-----------------------|
| Vapor Clean reiniging |
|-----------------------|

Opties kookplaat



| | | | |
|-------------------|----|---------------------------|--------------------|
| Kinderbeveiliging | Ja | Beperkt vermogensverbruik | 3700, 4800, 7400 W |
| ECO-Logic optie | Ja | Multizone optie | Ja |

Technische specificaties kookplaat



Totaal aantal kookzones 5

Linksvoor - Inductie - Multizone - 2.10 kW - Booster 2.30 kW - 21.0x19.0 cm

Linksachter - Inductie - Multizone - 1.60 kW - Booster 1.85 kW - 21.0x19.0 cm

Midden - Inductie - enkel - 2.30 kW - Booster 3.00 kW - Ø 27.0 cm

Rechtsachter - Inductie - enkel - 1.20 kW - Booster 1.40 kW - Ø 18.0 cm

Rechtsvoor - Inductie - enkel - 2.30 kW - Booster 3.00 kW - Ø 21.0 cm

| | | | |
|--|----|--|----|
| Aantal kookzones met booster | 5 | Indicator minimaal te gebruiken diameter | Ja |
| Number of Flexible zones | 1 | Indicator geselecteerde zone | Ja |
| Automatisch uitschakelen i.g.v. oververhitting | Ja | Indicator (lampje) restwarmte | Ja |
| Automatische aanpassing panafmeting | Ja | | |

Technische specificaties primaire oven



Aantal lampen 2

| | | | |
|--|--------------------|--|--------------------|
| Aantal ventilatoren | 2 | Uitneembaar glas binnendeur | Ja |
| Netto volume 1e oven | 115 l | Aantal ruiten ovendeur | 3 |
| Bruto volume, oven 1 | 129 l | Aantal thermo-reflecterende ruiten | 2 |
| Materiaal ovenruimte | Ever Clean emaille | Veiligheidsthermostaat | Ja |
| Aantal kookniveaus | 5 | Koelsysteem | Mantelkoeling |
| Type ovenrekken | Metalen zijsteunen | Afmetingen bruikbare interne ovenruimte (hxbxd) | 371x724x418 mm |
| Type licht | Halogeen | Temperatuurregeling | Elektro-mechanisch |
| Vermogen lamp | 40 W | Onderwarmte - vermogen | 1700 W |
| Opties bereidingstijdprogrammering | Begin en eind | Bovenwarmte - vermogen | 1200 W |
| Automatische inschakeling verlichting bij openen deur | Ja | Grill - vermogen | 1700 W |
| Opening deur | Neerwaarts | Grote vlakgrill - vermogen | 2900 W |
| Uitneembare ovendeur | Ja | Circulatie - vermogen | 2 x 1550 W |
| Volledig glazen binnendeur | Ja | Grill type | Elektrisch |
| | | Soft close systeem | Ja |

Opties primaire oven

| | | | |
|--------------------------------------|----|----------------------------|--------|
| Timer | Ja | Minimum temperatuur | 50 °C |
| Geluidssignaal einde kooktijd | Ja | Maximum temperatuur | 260 °C |

Meegeleverde accessoires primaire oven en kookplaat



| | | | |
|-----------------------------|---|--|---|
| Ovenrooster met stop | 1 | Inzetrooster | 1 |
| Bakplaat (20 mm) | 1 | Telescopische geleiders, gedeeltelijk uitschuifbaar | 1 |
| Bakplaat (40 mm) | 1 | Temperatuursonde | 1 |

Elektrische aansluiting

| | | | |
|--------------------------------|--------------|-------------------------|------------------------|
| Nominale aansluitwaarde | 10600 W | Type stroomkabel | Double and Three Phase |
| Stroom | 46 A | Frequentie | 50/60 Hz |
| Spanning | 220-240 V | Connection box | 5 polig |
| Spanning 2 (V) | 380-415 V | Stekker | Nee |
| Electric cable | Not included | | |

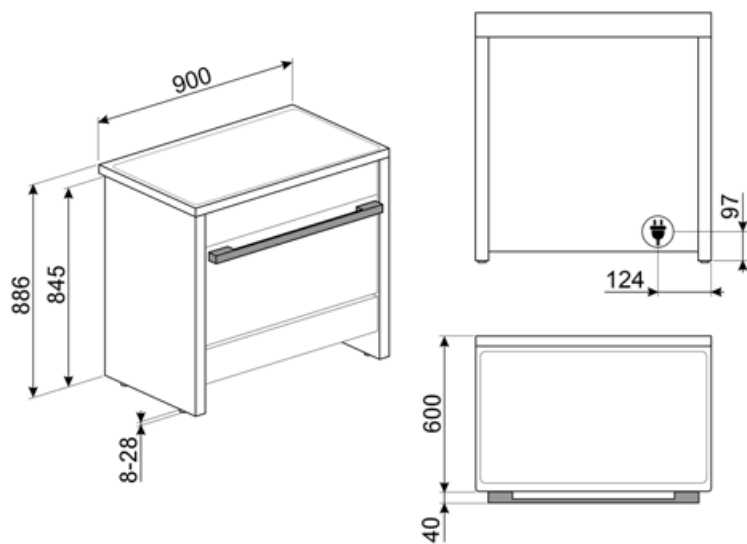

Compatible Accessories

AIRFRY



AIRFRY9

Air fryer rack AIRFRY . Ideal for recreating traditional frying in the oven, but with fewer calories and less fat. It allows you to cook quickly and simply dishes such as French fries, fried vegetables and fish, ensuring perfect browning and crispiness.



BBQ9

teflon-coated aluminum grid for 90 cm cavity



BN940

Enamelled tray 90 cm, 40 mm deep



GTP

Partially extractable telescopic guides (1 level), suitable for traditional ovens. Made in stainless steel, they guarantee stability and facilitate the smooth extraction of the trays.



KIT95B95A

Height extension kit 2 side and front panels (950mm), anthracite, for B95 cookers



PALPZ

Pizzapallet inox met ploibaar handvat, 315x325 mm



AIRFRY2

Air fryer tray. Ideal for recreating traditional frying in the oven, but with fewer calories and less fat. It allows you to cook quickly and simply dishes such as French fries, fried vegetables and fish, ensuring perfect browning and crispiness.



BBQ

Dubbelzijdig



BN920

Enamelled tray 90cm cavity, 20mm deep



GRILLPLATE

Universal griddle for induction, gas, ceramic and electric hobs. Non-stick surface ideal for cooking meat, cheese and vegetables. Dimensions: 410 x 240 mm.



GTT

Volledig uitschuifbare telescopische rails (1 niveau) voor traditionele ovens (SF-).



KITC9X9-1

Splashback kit, st/steel, 90cm, suitable for Portofino Multifunction, Master and Sinfonia cookers

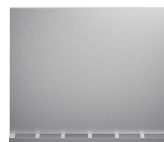

SCRP

Schraper voor inductie- en vitrokeramische kookplaten





SFLK1
Child lock





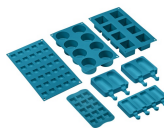





























TPKPLATE
Universal plate for induction, gas, ceramic and electric hobs. Non-stick surface ideal for cooking fish, eggs and vegetables. Dimensions: 410 X 240 mm.



SMOLD
Set van 7 siliconen vormen voor ijsjes, pralines, ijsblokjes of porties. -60°C tot 230°C.

Symbols glossary

| | |
|--|--|
|  Energy efficiency class A |  Power booster: option allows the zone to work at full power when very intense cooking is necessary. |
|  Sommige modellen zijn voorzien van een functie om het programma/de cyclus te blokkeren zodat het niet per ongeluk kan aangepast worden. |  Installation in column: Installation in column. |
|  Air cooling system: to ensure a safe surface temperatures. |  Defrost by time: Manual defrost function. At the end of the set duration, the function stops. |
|  Triple glazed doors: Number of glazed doors. |  ECO-logic: option allows you to restrict the power limit of the appliance real energy saving. |
|  Ever Clean Enamel: Ever Clean enamel is applied electrostatically, corner to corner and edge to edge to prevent cracking or cracks over time. It is a particular pyrolytic enamel, resistant to acids which, in addition to being pleasantly bright, promotes greater cleaning of the oven walls, thanks to its lower porosity. It is baked at over 850 °C and slowly polymerized at a scientifically determined rate to ensure uniform depth and strength. Ever Clean enamel creates an impeccable finish both on the inside of the oven and on the trays, making the surfaces of the oven incredibly easy to maintain over time as it reduces the adhesion of fat during cooking. |  Circogas: In gasovens verdeelt de ventilator de warmte snel en gelijkmatig over de ovenruimte, waardoor smaakoverdracht wordt vermeden bij het tegelijkertijd bereiden van een aantal verschillende gerechten. In elektrische ovens voltooit deze combinatie het koken van voedsel dat aan de oppervlakte klaar is, maar dat van binnen meer moet worden gekookt, zonder verder bruin te worden. |
|  Ventilator met bovenste en onderste elementen: De elementen in combinatie met de ventilator zijn bedoeld om een meer gelijkmatige warmte te bieden, een methode die vergelijkbaar is met conventioneel koken, dus voorverwarmen is vereist. Het meest geschikt voor items die langzaam koken vereisen. |  Alleen boven- en onder element: een traditionele kookmethode die het meest geschikt is voor losse items in het midden van de oven. de bovenkant van de oven zal altijd het heetst zijn. Ideaal voor gebraden vlees, fruitcake, brood etc. |
|  Base: the heat comes only from the bottom of the cavity. The fan is not active. Ideal for sweet and savory pies, cobblers and pizzas. Designed to complete cooking and make food more crunchy. This symbol in gas ovens indicates the gas burner. |  Circulaire: De combinatie van de ventilator en het ronde element eromheen zorgt voor een hete lucht kookmethode. Dit biedt vele voordelen, waaronder geen voorverwarmen als de kooktijd meer dan 20 minuten bedraagt, geen smaakoverdracht bij het gelijktijdig bereiden van verschillende soorten voedsel, minder energie en kortere kooktijden. Geschikt voor alle soorten voedsel. |
|  De combinatie van de grill, de ventilator en onderwarmte is interessant voor het bereiden van kleine hoeveelheden. |  Grill: Very intense heat coming only from above from a double heating element. The fan is not active. Provides excellent grilling and gratinating results. Used at the end of cooking, it gives a uniform browning to dishes. |
|  Fan grill: very intense heat coming only from above from a double heating element. The fan is active. It allows the optimal grilling of thickest meats. Ideal for large cuts of meat. |  Overheat protection: The safety system that automatically turns off the hob in case of overheating of the control unit. |

-
- | | | | |
|--|---|---|---|
|  | Induction: The work of these hobs is based on the principle of electromagnetic induction. The heat is generated directly in the bottom of the pan during its contact with the hob. |  | All glass inner door: All glass inner door, a single flat surface which is simple to keep clean. |
|  | The inner door glass: can be removed with a few quick movements for cleaning. |  | Side lights: Two opposing side lights increase visibility inside the oven. |
|  | Automatic opening: some models have Automatic opening door when the cycle is finished which is a perfect solution for handle-less kitchen units as no handle is needed. For safety reasons, the door locks automatically when the machine is in use to avoid it being opened inadvertently. |  | Indication of residual heat: After the glass ceramic hob is switched off the residual heat indicator shows which of the heating zones still remains hot. When the temperature drops below 60 ° C, the indicator goes out. |
|  | The oven cavity has 5 different cooking levels. |  | Alle modellen zijn voorzien van een soft close deursysteem waarbij de deur zacht en stil sluit. |
|  | Telescopic rails: allow you to pull out the dish and check it without having to remove it from the oven entirely. |  | Vapor Clean: a simple cleaning function using steam to loosen deposits in the oven cavity. |
|  | The capacity indicates the amount of usable space in the oven cavity in litres. |  | DIGI screen display + bedieningsknoppen |
|  | Knobs control |  | Automatic merge of zones for a bigger area |