

BM30URXI



Product Family	Refrigerator
Installation	Free standing
Category	Bottom Mount
Sistema Total No - Frost	Total
Cooling type	Total No Frost - Double Cooling system
Defrost	Automatic
Hinge type	Standard
Hinge position	Right
Counter-depth	Yes
EAN code	8017709344030



Aesthetics



Aesthetic	SPR	Side material	Steel
Colour	Stainless steel	Side colour	Stainless steel
Material	Stainless steel	Logo	Applied
Door steel type	Normal	Door shelves profile color	Silver
Handle	External	Drawers profile color	Silver
Handle type	Fixed	Color of glass shelf profile	Silver
Handle colour	Stainless steel	Display	LED
Logo colour	Stainless Steel	Display porition	Interno (sul Top)

Refrigerator compartment features



Number of compartments	3	Crisper Cover	Yes
Compartment types	Low temperature compartment, Fruit and vegetable compartment	Type of crisper/vegetable drawers cover	Glass
No. of adjustable shelves	2	No. of lights refrigerator compartment	1
Number of fruit and vegetables drawers	2	Low temperature compartment	Yes
Shelves material	Glass	Internal light in fridge	Yes
		Type of internal light (fridge)	LED

Type of crisper/vegetable drawers cover Standard

Refrigerator Inner Door

Number of adjustable door shelves 4 No. of bottle shelves 1

Other Refrigerator features



Humidity Control Yes Fan Yes
MultiFlow Yes

Freezer compartment features

Number of drawers 2 Type of internal light (freezer) LED
No. of lights freezer compartment 2 Type of shelves Glass
Internal light in freezer Yes

Other Freezer features

Accessories 1 ice box Daily ice production 1.3 kg
Ice maker Automatic Ice shape Cubes

Other technical features

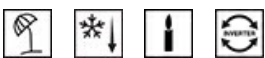

Functions display Holiday, Fast freezing, Sabbath
Fast freezing button Yes
Water network connection Yes
Power on lamp Yes
Temperature alarm lamp Yes
Door open alarm Yes
Type of temperature control Electronic
No. of compressors 1
Refrigerant gas type R600a
Type of compressor Inverter
No. of evaporators 2
Foam agent Cyclopentane

Performance / Energy Label - Reg. 2019

Total net volume 16.1 cu. ft.

Sum of the volumes of the frozen compartment(s)	5.2 cu. ft.	Gross volume frozen food compartment	5.8 cu. ft.
Sum of the volumes of the chill compartment(s) and the unfrozen compartment(s)	10.9 cu. ft.	Fresh Food compartment - Gross Volume	11.7 cu. ft.

Electrical Connection







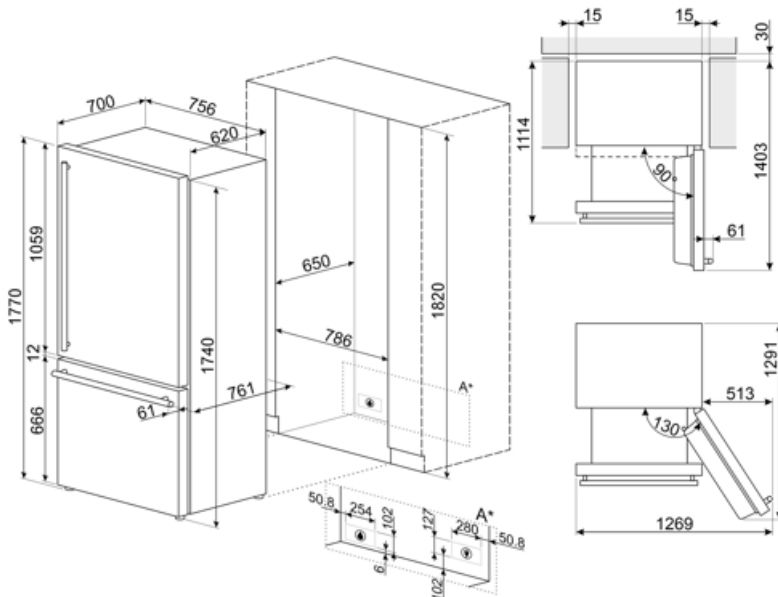

Electrical connection rating	200 W	Frequency (Hz)	60 Hz
Current	2 A	Power supply cable length	83 1/16 "
Voltage (V)	120 V	Plug	(B) NEMA 5-15P

Logistic Information

Width	29 3/4 "	Product width with maximum doors opening	49 15/16 "
Depth without handle	27 9/16 "	Product depth with handle	29 13/16 "
Height	68 1/2 "	Product depth with doors open at 90°	55 1/4 "



Symbols glossary

- | | | | |
|--|--|---|---|
|  | The automatic defrost system works by automatically defrosting at regular intervals eliminating the need to defrost altogether. |  | LED display: to show programmes, functions and options selected and the time to the end of the cycle. |
|  | Ventilated: Forced distribution of cold air in the refrigerator compartment, which allows even temperature distribution within the fridge. |  | Fast freezing: The fast freezing function brings the temperature of the compartment down when activated a few hours prior to usage. |
|  | Power saving mode: The power saving mode allows you to disable the refrigerator and keep the freezer working. |  | LED interior lighting: is a more energy efficient and long lasting way of illuminating the interior of the appliance. |
|  | Smeg's evolution towards more intelligent and eco-friendly models has led to the choice of Inverter technology, which significantly reduces consumption. |  | Air plus: keeps food fresher for longer. |
|  | SABBATH: function that allows to cook food respecting Judaism's day of rest provisions. | | |