

## C3170NE



Product familie	Koelkast
Installatie	Inbouw
Categorie	Koel-vriescombinatie
Inbouwnis	178
Referentie breedte	Tot 60 cm cm
Referentie hoogte	160 - 200 cm cm
Type koelen	Geventileerde koelkast, No Frost vriezer
Ontdooien	Automatisch ontdooien
Type scharnier	Bevestiging met geleiders
Positie scharnier	Rechts
Deur omkeerbaar	Ja
EAN-code	8017709293390



## Design

Design	Universeel	Kleur zijkanten	Wit
Kleur	Wit	Logo	Geëtst
Materiaal deur	Plaatstaal	Kleur profielen binnenzijde	Zilver
Kleur logo	Zilver	Kleur profielen laden	Zilver
Materiaal zijwanden	Staal	Kleur profiel glazen leggers	Chroom

## Uitrusting koelkast



Number of compartments	1	Afdekplaat groentenlade	Ja
Compartment types	Fruit and vegetable compartment	Flessenhouder	Ja
Aantal verstelbare leggers	3	Type afdekplaat groente-/fruitlade	Glas
Aantal groente-/fruitlades	1	Convertible temperature drawer	No
Shelves material	Glas	Binnenverlichting koelkast	Ja
Type afdekplaat groente-/fruitlade	Standaard	Type binnenverlichting koelkast	LED

## Binnendeur koelkast

Aantal verstelbare binnendeurcompartimenten	3	Aantal flessenhouders	1
---	---	-----------------------	---

## Overige features koelkast



Humidity Control	No	Ventilator	Ja
Accessoires	Eierhouder		

## Uitrusting vriezer

Aantal lades	3	Aantal legplanken	2
--------------	---	-------------------	---

## Overige features vriezer

Accessoires	1 ijsblokeshouder
-------------	-------------------

## Overige technische eigenschappen



Type temperatuurcontrole	Meccanico
Aantal compressoren	1
Type koelgas	R600a
Type compressor	Variabele toeren
Hoeveelheid koelmiddel	44 g
Schuimmiddel	Cyclopentaan

## Prestaties/Energie label - Reg. 2019



Annual energy consumption	224 kWh/jaar	Geluidsniveau	38 dB(A) re 1 pW
Energie-efficiëntieklasse	E	Conserveringsduur zonder stroom	13 h
Emissieklasse voor akoestisch luchtgeluid	C	4 star - Freezing capacity	3,2 kg/24h
Totaal netto volume	262 l	Klimaatklasse	SN, T
Netto inhoud vriesgedeelte	69 l	EEl	99 %
Netto inhoud koelgedeeltes	193 l		

## Elektrische aansluiting

Nominale aansluitwaarde	125 W	Frequentie (Hz)	50 Hz
Stroom (A)	0,8 A	Lengte stroomkabel	150 cm
Spanning (V)	220-240 V	Stekker	(F;E) Schuko







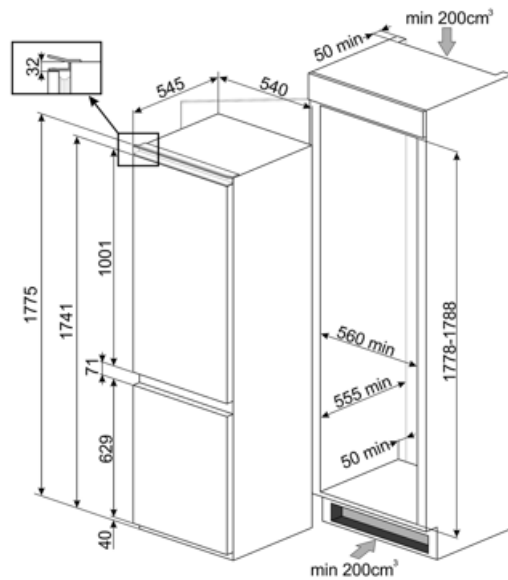

## Logistieke informatie

Breedte product (mm) 540 mm  
Diepte zonder handvat 545 mm  
en spacer

Maximum hoogte 1775 mm  
Product breedte met  
maximale deuropening 540 mm



## Symbols glossary

-  4 stars freezing compartment for better food preservation.
-  The automatic defrost system works by automatically defrosting at regular intervals eliminating the need to defrost altogether.
-  LED interior lighting: is a more energy efficient and long lasting way of illuminating the interior of the appliance.
-  Built-in niche
-  Energie-efficiëntieklasse
-  A++: Energy efficiency class A++ helps to save up to 20% energy compared to class A. Maximum performance with minimum consumption is guaranteed.
-  Geventileerd: een geforceerde verdeling van koude lucht in het koelkast compartiment, die een gelijke temperatuurverdeling verzekert in de koelkast.
-  De evolutie van Smeg vaatwassers naar meer intelligente en milieuvriendelijke modellen heeft ertoe geleid om de inverter technologie te gebruiken, die een significante energie- en geluidsbesparing met zich meebrengt.
-  No Frost: The No Frost and Frost free systems prevent ice from forming so that no defrosting is required.