

C81721EI



Product Family	Refrigerator
Installation	Built-in
Category	Bottom Mount
Built-in niche	178
Reference width	Until 60
Reference height	160 - 200
Cooling type	Fan assisted
Defrost	Automatic for refrigerator, manual for freezer
Hinge type	Sliding
Hinge position	Right
Reversible door	Yes
EAN code	8017709323974



Aesthetics

			
Aesthetic	Universale	Door shelves profile color	Silver
Colour	White	Drawers profile color	Silver
Material	Metal sheet	Color of glass shelf profile	Chrome
Side material	Steel	Display	LED
Side colour	White	Display position	Interno (cella frigo)
Logo	Silk screen		

Refrigerator compartment features

			
No. of adjustable shelves	4	Crisper Cover	Yes
Number of fruit and vegetables drawers	2	Type of crisper/vegetable drawers cover	Glass
Type of adjustable shelves	Glass	Internal light in fridge	Yes
Type of crisper/vegetable drawers cover	Standard	Type of internal light (fridge)	LED

Refrigerator Inner Door

No. of door shelves with transparent cover	1	No. of bottle shelves	1
---	---	------------------------------	---

Number of adjustable door shelves 2

Other Refrigerator features



Accessories Egg tray Fan Yes

Freezer compartment features

Number of drawers 3

Other Freezer features

Accessories 1 ice box

Other technical features

Type of temperature control	Electro-mechanical
No. of compressors	1
Refrigerant gas type	R600a
Type of compressor	Standard
Refrigerant Quantity (gr)	72 g
Foam agent	Cyclopentane

Performance / Energy Label NEW 2019



Annual energy consumption	220 kWh/a	Airborne acoustical noise emissions	34 dB(A) re 1 pW
Energy efficiency class	E	Temperature Rise Time	11.50 h
Airborne acoustical noise emission class	B	4 star - Freezing capacity	3.3 Kg/24h
Total net volume	269 l	Climate class	SN, N, ST, T
Sum of the volumes of the frozen compartment(s)	73 l	EEl	100 %
Sum of the volumes of the chill compartment(s) and the unfrozen compartment(s)	196 l		

Electrical Connection

Plug	(F;E) Schuko	Voltage (V)	230-240 V
		Frequency (Hz)	50 Hz





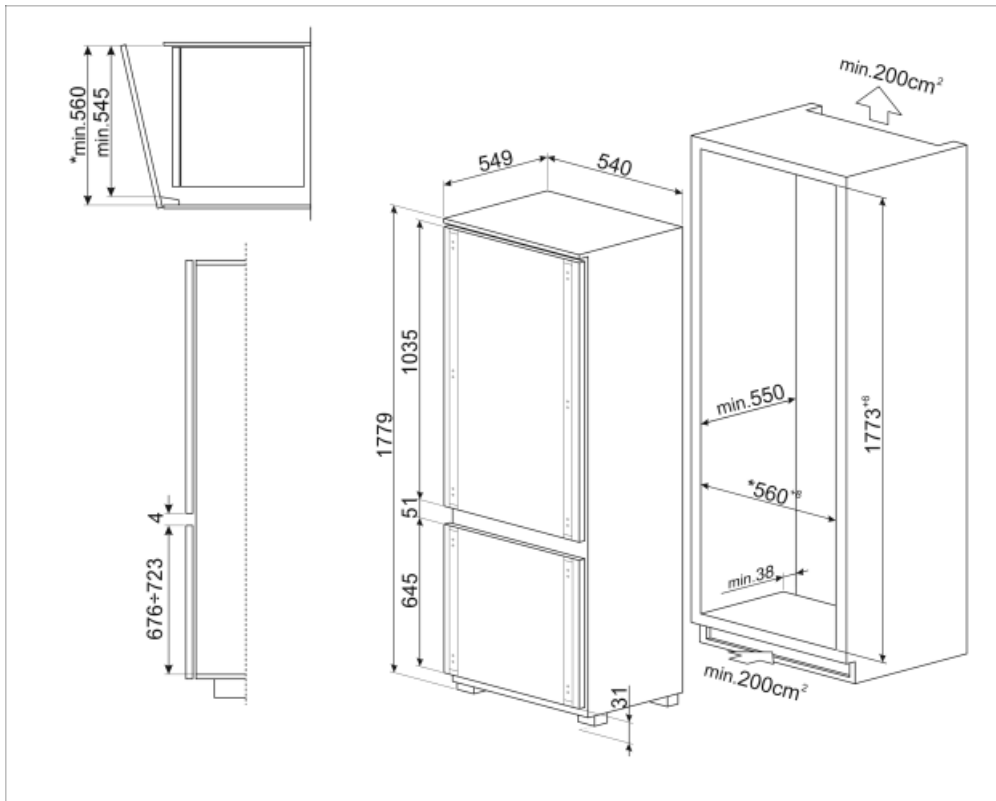

Electrical connection rating 140 W

Power supply cable length 240 cm

Current 1.1 A



Symbols glossary (TT)

	The automatic defrost system works by automatically defrosting at regular intervals eliminating the need to defrost altogether.		Energy efficiency class E
	LED display: to show programmes, functions and options selected and the time to the end of the cycle.		Ventilated: Forced distribution of cold air in the refrigerator compartment, which allows even temperature distribution within the fridge.
	LED interior lighting: is a more energy efficient and long lasting way of illuminating the interior of the appliance.		Built-in niche