

C9174TN5D



Product Family	Refrigerator
Installation	Built-in
Category	Bottom Mount
Built-in niche	178
Reference width	Until 60 cm
Reference height	160 - 200 cm
Sistema Total No - Frost	Total
Cooling type	Total No Frost - Double Cooling system
Defrost	Automatic
Hinge type	Sliding
Kitchen panel	Not supplied
Hinge position	Right
Reversible door	Yes
EAN code	8017709337223



Aesthetics



Aesthetic	Universale	Door shelves profile color	Silver
Colour	White	Drawers profile color	Silver
Material	Metal sheet	Color of glass shelf profile	Silver
Side material	Steel	Display	LCD Touch
Side colour	White	Display position	Interno (sul Top)
Logo	Silk screen		

Refrigerator compartment features



No. of adjustable shelves	3	Type of crisper/vegetable drawers cover	Glass
Number of fruit and vegetables drawers	2	No. of lights refrigerator compartment	3
Shelves material	Glass	Internal light in fridge	Yes
Type of crisper/vegetable drawers cover	On sliding rails	Type of internal light (fridge)	LED
Crisper Cover	Yes		

Refrigerator Inner Door

No. of door shelves with transparent cover	1	No. of bottle shelves	1
---	---	------------------------------	---

Number of adjustable door shelves 2

Other Refrigerator features



Accessories
MultiFlow

Egg tray
Metal

Fan

Yes

Freezer compartment features

Number of drawers 3

Other Freezer features

Accessories 1 ice box

Other technical features

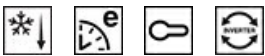

Functions display

Fast freezing, Fast cooling, ECO, Control lock, Temperature alarm, Cooling timer

Temperature alarm lamp

Yes

Door open alarm

Yes

Temperature Alarm

Yes

Type of temperature control

Electronic

No. of compressors

1

Refrigerant gas type

R600a

Type of compressor

Inverter

Foam agent

Cyclopentane

Performance / Energy Label - Reg. 2019



Annual energy consumption 173 kWh/a

Energy efficiency class D

Airborne acoustical noise emission class B

Total net volume 248 l

Sum of the volumes of the frozen compartment(s) 62 l

Sum of the volumes of the chill compartment(s) and the unfrozen compartment(s) 186 l

Airborne acoustical noise emissions 35 dB(A) re 1 pW

Temperature Rise Time 11 h

4 star - Freezing capacity 7,5 kg/24h

Climate class SN, N, ST, T

EEL 80 %

Electrical Connection







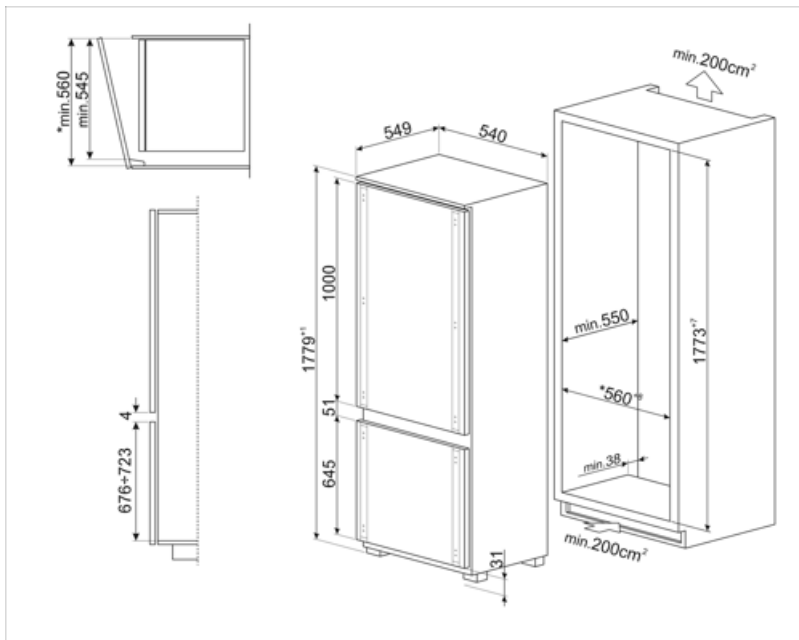



Electrical connection rating	140 W	Frequency (Hz)	50 Hz
Current	1,1 A	Power supply cable length	240 cm
Voltage (V)	230-240 V	Plug	(F;E) Schuko

Logistic Information

Width	546 mm	Height	1772 mm
Width of the built-in niche	560 mm	Height of the built-in niche	1780 mm
Depth without handle	549 mm	Product width with maximum doors opening	548 mm
Depth of the built-in niche	550 mm		



Symbols glossary

- | | | | |
|---|---|---|--|
|  | The automatic defrost system works by automatically defrosting at regular intervals eliminating the need to defrost altogether. |  | Child lock: some models are fitted with a device to lock the programme/cycle so it cannot be accidentally changed. |
|  | LCD display: to optimize performance and simplify the use of the appliance. |  | Economical mode: Analyzes fridge functioning during the activation and optimizes the operating cycle in order to reduce power consumption. |
|  | Ventilated: Forced distribution of cold air in the refrigerator compartment, which allows even temperature distribution within the fridge. |  | Fast freezing: The fast freezing function brings the temperature of the compartment down when activated a few hours prior to usage. |
|  | LED interior lighting: is a more energy efficient and long lasting way of illuminating the interior of the appliance. |  | Smeg's evolution towards more intelligent and eco-friendly models has led to the choice of Inverter technology, which significantly reduces consumption. |
|  | Built-in niche |  | Energy efficiency class D |
|  | Multiflow Cooling System: the Multiflow ventilation system allows an even distribution of cool air around the fridge cabinet. The stainless steel panel gives a more premium look to the appliance. | | |