

C9174TN5D



Product Family	Refrigerator
Installation	Built-in
Category	Bottom Mount
Built-in niche	178
Reference width	Until 60
Reference height	160 - 200
Sistema Total No - Frost	Total
Cooling type	Total sem geada - Sistema de arrefecimento duplo
Defrost	Automatic
Hinge type	Sliding
Hinge position	Right
Reversible door	Yes
EAN code	8017709337223



Aesthetics



Aesthetic	Universal	Cor do perfil das gavetas	Silver
Colour	White	Cor do perfil da prateleira de vidro	Silver
Material	Metal sheet	Display	LCD Touch
Side material	Steel	Mostrar porções	Interno (no Topo)
Side colour	White	Dispenser	No
Logotipo	Logotipo serigrafado	Water Filter	No
Cor do perfil das prateleiras da porta	Silver		

Refrigerator compartment features



No. of adjustable shelves	3	Nº de lâmpadas	3
Number of fruit and vegetables drawers	2	Life Plus zone-0°C	No
Type of adjustable shelves	Glass	Convertible temperature drawer	No
Type of crisper/vegetable drawers cover	On sliding rails	Compartimento baixa temperatura	No
Crisper Cover	Yes	Internal light in fridge	Yes
Bottle shelf	No	Type of internal light (fridge)	LED
Type of crisper/vegetable drawers cover	Glass		

Refrigerator Inner Door

No. of door shelves with transparent cover	1	No. of bottle shelves	1
Number of adjustable door shelves	2	Bottle shelves with wire support	No
Adjustable door shelves with wire support	No		

Other Refrigerator features



Accessories	Egg tray	Fan	Yes
Natural Plus Blu Light	No	Ionizer	No
MultiFlow	Metal		

Freezer compartment features

Number of drawers	3	Type of internal light (freezer)	No
Internal light in freezer	No		

Freezer Inner Door

Pizza box	No
-----------	----

Other Freezer features

Accessories	1 ice box	Fast freezing compartment	No
Manual ice maker	No	Ice tray shelf	No
Ice maker	No		

Other technical features

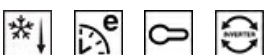

Functions display	Fast freezing, Fast cooling, ECO, Control lock, Temperature alarm, Cooling timer
MultiZone	No
Ligação à rede de água	No
Temperature alarm lamp	Yes
Door open alarm	Yes
Temperature Alarm	Yes
Type of temperature control	Electronic
No. of compressors	1
Refrigerant gas type	R600a

Type of compressor
Espuma expansiva de isolamento

Inverter
Ciclopentano

Etiqueta de Desempenho / Energia - Reg. 2019







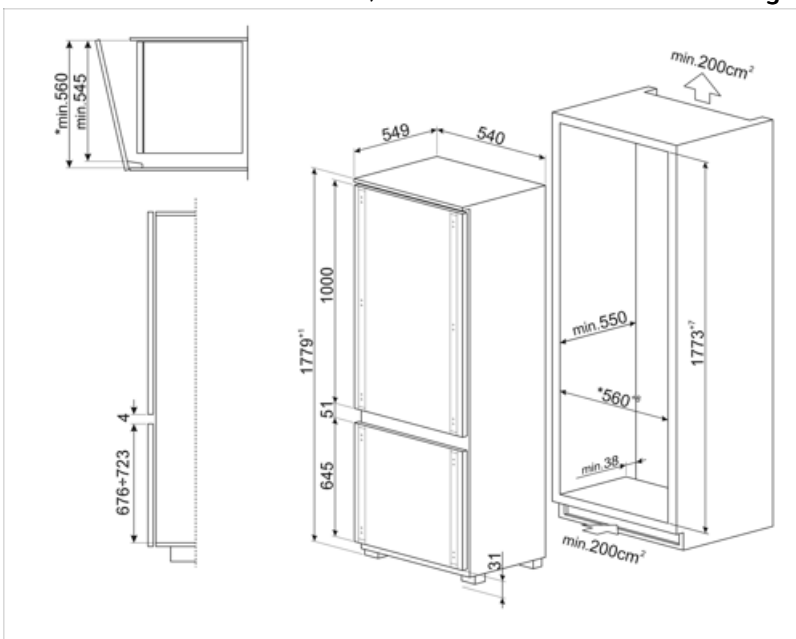



			
Consumo de energia anual	173 kWh/a	Airborne acoustical noise emissions	35 dB(A) re 1 pW
Classe de eficiência energética	D	Autonomia de conservação sem energia elétrica	11 h
Classe de emissão de ruído acústico aerotransportado	B	4 estrelas - Capacidade de congelamento	7.5 Kg/24h
Volume líquido total	248 l	Classe climática	SN, N, ST, T
Soma dos volumes do(s) compartimento(s) congelado(s)	62 l	EEl	80 %
Soma dos volumes do(s) compartimento(s) refrigerado(s) e do(s) compartimento(s) não congelado(s)	186 l		

Electrical Connection

Plug	(F;E) Schuko	Voltage (V)	230-240 V
Electrical connection rating	140 W	Frequency (Hz)	50 Hz
Current	1,1 A	Power supply cable length	240 cm



Symbols glossary

-  O sistema de descongelamento automático funciona descongelando automaticamente em intervalos regulares, eliminando a necessidade de descongelar completamente.
-  Classe de eficiência energética D
-  Modo económico: Analisa o funcionamento da geladeira durante a ativação e otimiza o ciclo de funcionamento, a fim de reduzir o consumo de energia.
-  CONGELAMENTO RÁPIDO: A função de congelamento rápido reduz a temperatura do compartimento quando ativado algumas horas antes do uso.
-  Tecnologia do inversor: A evolução dos secadores Smeg para modelos mais inteligentes e ambientalmente sustentáveis levou à escolha do uso da tecnologia do inversor com bombas de calor, o que reduz significativamente o consumo de energia.
-  Multiflow Cooling System: the Multiflow ventilation system allows an even distribution of cool air around the fridge cabinet. The stainless steel panel gives a more premium look to the appliance.
-  Bloqueio para crianças: alguns modelos estão equipados com um dispositivo para bloquear o programa/ciclo para que não possa ser acidentalmente alterado.
-  Display LCD: para otimizar o desempenho e simplificar o uso do aparelho.
-  Ventilado: Distribuição forçada de ar frio no compartimento da geladeira, o que permite uma distribuição uniforme da temperatura dentro da geladeira.
-  Iluminação interior LED: é uma forma mais eficiente em termos energéticos e duradoura de iluminar o interior do aparelho.
-  Nicho incorporado

Benefit (TT)

No-Frost system

The No Frost system prevents the formation of ice and contributes to better preservation of food in the refrigerator

Metallic Multiflow system

The metal Multiflow system ensures an even distribution of cold air inside the refrigerator, which diffuses through an elegant stainless steel panel

A back panel with a series of openings ensures uniform circulation of cold air around each shelf of the refrigerator. This advanced air recirculation system ensures a constant temperature and humidity level, preserving food freshness for longer and helping to reduce food waste significantly

Fan

The fan contributes to an even distribution of air inside the refrigerator

Refrigerant gas R600a

Environmentally friendly R600a refrigerant gas contributes to rapid cooling with lower energy consumption

Refrigerator Internal lighting

Interior lighting for perfect visibility of shelves in the refrigerator compartment

Fruit and vegetable drawer

The fruit and vegetable drawer ensures the best storage conditions for fresh food, avoiding any contamination

Inverter compressor

Inverter compressor reduces noise and vibration levels for a quiet and comfortable kitchen environment

Inverter compressor technology offers significant advantages for refrigeration systems, improving both performance and efficiency. Better temperature control ensures a more stable and constant indoor environment, preserving the freshness of food. This technology also results in reduced energy consumption, as the compressor adjusts its speed according to cooling needs.

Internal display

Internal display for targeted temperature control and a clean, minimalist design