

CPF120IGMPX

Cooker size	120x60 cm
N.º de cavidades com rótulo energético	2
Fonte de calor da cavidade	ELECTRICITY
Hob type	Mixed
Tipo de forno principal	Thermo-ventilated
Type of second oven	Thermo-ventilated
Sistema de limpeza no forno principal	Pyrolitic
EAN code	8017709278267
Energy efficiency class	A+
Energy efficiency class, second cavity	A



Aesthetics











Aesthetic Design	Portofino	Controls colour	Stainless steel
Colour	Flush fit	No. of controls	11
Acabamento	Stainless steel	Cor da serigrafia	Serigrafia em preto
Command panel finish	Satin	Display	Touch
Logo	Finger friendly stainless steel	Door	With frame
Posição do logotipo	Logotipo aplicado	Glass type	Black
Upstand	Logotipo no painel abaixo do forno	Handle	Smeg Portofino
Cor da placa	Yes	Handle Colour	Brushed stainless steel
Type of pan stands	Stainless steel	Storage compartment	Drawer
Type of control setting	Cast Iron	Sliding compartment	Yes
Control knobs	Control knobs	Plinth	Black
	Smeg Portofino		

Programs / Functions

No. of cooking functions	9
--------------------------	---

Traditional cooking functions

 Static	 Fan assisted	 Circulaire
 Turbo	 Eco	 Small grill
 Large grill	 Fan grill (large)	 Fan assisted bottom







Cleaning functions

 Pyrolytic
--

Programs / Functions Auxiliary Oven

Funções de cozedura cavidade 2 8

Funções tradicionais de cozimento, cavidade 2

 Static	 Fan assisted	 Circulaire
 Eco	 Large grill	 Fan grill (large)
		

Parte inferior assistida por ventilador

Funções de cozedura com tecnologia Vapor Direto



Ventilador forçado (aquecimento

circular + ventilador)

Funções de limpeza cavidade 2

 Vapor clean
--

Hob technical features



Total no. of cook zones 6

Central esquerda - Gas - 2UR (dual) - 4.20 kW

Front centre - Gas - Semi Rapid - 1.80 kW

Rear centre - Gas - Rapid - 3.00 kW

Front right - Induction - multizone - 2.10 kW - Booster 2.30 kW - 21.1x19.1 cm

Rear right - Induction - multizone - 1.60 kW - Booster 1.85 kW - 21.0x19.0 cm

Central - Teppanyaki - 1.40 kW

Number of Flexible zones	1	Automatic switch off when overflow	No
Type of gas burners	Standard	Automatic pan detection	Yes
Automatic electronic ignition	Yes	Minimum pan diameter indication	Yes
Burner caps	Matt black enamelled	Selected zone indicator	Yes
Automatic switch off when overheat	Yes	Residual heat indicator	Yes

Main Oven Technical Features



No. of lights	2	Total no. of door glasses	4
Fan number	1	No. of thermo-reflective door glasses	3
Net volume of the cavity	70 l	Safety Thermostat	Yes
Gross volume, 1st cavity	79 l	Heating suspended when door is opened	Yes
Cavity material	Ever Clean enamel	Cooling system	Tangential
No. of shelves	5	Door Lock During Pyrolysis	Yes
Type of shelves	Metal racks	Usable cavity space dimensions (HxWxD)	360X460X425 mm
Roof Liner	No	Temperature control	Electro-mechanical
Light type	Halogen	Lower heating element power	1200 W
Light Power	40 W	Upper heating element - Power	1000 W
Cooking time setting	Start and Stop	Grill element	1700 W
Light when oven door is open	Yes	Large grill - Power	2700 W
Door opening	Flap down	Circular heating element - Power	2000 W
Removable door	Yes	Grill type	Electric
Full glass inner door	Yes	Soft Close system	Yes
Removable inner door	Yes		

Options Main Oven

Timer	Yes	Minimum Temperature	50 °C
End of cooking acoustic alarm	Yes	Maximum temperature	280 °C

Second Oven Technical Features



Net volume of the second cavity	63 l	No. total door glasses	3
Gross volume, 2nd cavity	79 l	No. thermo-reflective door glasses	2
Cavity material	Ever Clean enamel	Safety Thermostat	Yes
No. of shelves	5	Heating suspended when door is opened	Yes

Type of shelves	Metal racks	Cooling system	Tangential
Roof Liner	No	Usable cavity space dimensions (HxWxD)	360X460X425 mm
No. of lights	2	Temperature control	Electro-mechanical
Light type	Halogen	Lower heating element - power	1200 W
Light Power	40 W	Upper heating element - Power	1000 W
Cooking time setting	Start and Stop	Grill element - power	1700 W
Light when oven door is open	Yes	Large grill - Power	2700 W
Door opening	Flap down	Potência da resistência circular	2000 W
Removable door	Yes	Grill type	Electric
Full glass inner door	Yes	Tilting grill	Yes
Removable inner door	Yes	Soft Close system	Yes

Options Auxiliary Oven

Timer	Yes	Minimum Temperature	50 °C
End of cooking acoustic alarm	Yes	Maximum temperature	260 °C

Accessories included for Main Oven & Hob



Rack com batente traseiro e lateral	1	Grill mesh	1
20mm deep tray	1	Telescopic Guide rails, total Extraction	1
40mm deep tray	1	Sonda de carne	1

Accessories included for Secondary Oven



Rack com batente traseiro e lateral	1	Grill mesh	1
20mm deep tray	1	Telescopic Guide rails, total Extraction	1
40mm deep tray	1		

Electrical Connection

Plug	No	Electric cable	Installed, Single phase
Electrical connection rating	10900 W	cabo de alimentação de teste	Sim
Current	32 A	Type of electric cable	Double and Three Phase
Voltage	220-240 V	Frequency	50/60 Hz
Voltage 2 (V)	380-415 V	Bloco de terminais	5 polos

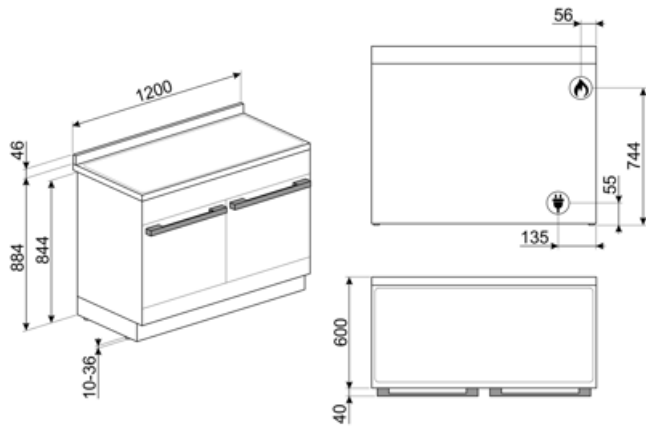

Compatible Accessories

AIRFRY

Air fryer rack AIRFRY . Ideal for recreating traditional frying in the oven, but with fewer calories and less fat. It allows you to cook quickly and simply dishes such as French fries, fried vegetables and fish, ensuring perfect browning and crispiness.



BGTR4110

Placa para grelhar de ferro fundido adequada para fogões Victoria TR4110



BN640

Tabuleiro esmaltado, 40mm de profundidade



GRILLPLATE

Placa de rede universal para indução, gás, cerâmica e fogões elétricos. Superfície antiaderente ideal para cozinhar carne, queijo e vegetais. Dimensões: 410 x 240 mm.



GTT

** Guias telescópicas totalmente extraíveis (1 nível)** Extração: 433 mm Material: Aço inoxidável AISI 430 polido



KITH95CPF120

Kit extensão de altura (950 mm), adequado para fogões TR4110



PALPZ

Pá para pizza com alça dobrável largura: 315mm comprimento : 325mm



SFLK1

Bloqueio para crianças



TPKPLATE

Placa universal para placas de indução, gás, cerâmica e fogões elétricos. Superfície antiaderente ideal para cozinhar peixe, ovos e vegetais. Dimensões: 410 X 240 mm.



BBQ

Double sided plate BBQ. Suitable for recreating succulent and crispy dishes in the oven with the typical taste of grilled cooking. The ribbed side is particularly suitable for meats and cheeses. The smooth side for fish, seafood and vegetables.



BN620-1

Tabuleiro esmaltado, 20mm de profundidade



BNP608T

Bandeja revestida de teflon, 8mm de profundidade, a ser colocada na grade



GTP

** Guias telescópicas parcialmente extraíveis (1 nível)** Extração: 300 mm Material: Aço inoxidável AISI 430 polido



KIT1CPF120X

Painel anti-salpicos 120x60 cm, aço inoxidável, adequado para fogões Portofino



KITP65CPF120

Kit extensão de profundidade (650 mm), adequado para fogões TR4110



SCRP

Placas de indução e de cerâmica e raspador teppanyaki



SMOLD

Conjunto de 7 moldes de silicone para sorvetes, gelados, pralinés, cubos de gelo ou para porção de alimentos. Utilizável de -60°C a +230°C

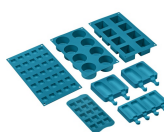

WOKGHU

Suporte de ferro fundido para WOK



Alternative products



CPF120IGMPWH
Colour: White



CPF120IGMPR
Colour: Red



































CPF120IGMPBL
Colour: Black











CPF120IGMPT
Colour: Turquesa

Symbols glossary

	Fusão automática de zonas para uma área maior		Suportes de ferro fundido para serviço pesado: para máxima estabilidade e resistência.
	R: Desempenho de secagem do produto, medido de A++ a D/G, dependendo da família de produtos		A+: A classe de eficiência energética A+ ajuda a economizar até 10% de energia em comparação com a classe A. O desempenho máximo com consumo mínimo é garantido.
	Instalação em coluna: Instalação em coluna		Controle dos botões
	Sistema de arrefecimento a ar: para garantir temperaturas de superfície seguras.		Um forno A VAPOR DIRETO tem 1 função de cozedura a vapor à qual o utilizador PODE adicionar vapor MANUALMENTE. A função é ativada quando o utilizador liga a função
	Portas envidraçadas triplas: Número de portas envidraçadas.		Quádruplo vidro: Número de portas envidraçadas.
	ECO-logic: opção permite-lhe restringir o limite de potência da poupança de energia real do aparelho.		Interior esmaltado: O interior em esmalte de todos os fornos Smeg tem um revestimento antiácido especial que ajuda a manter o interior limpo, reduzindo a quantidade de gordura de cozimento aderente a ele.
	Aço inoxidável à prova de dedadas: O aço inoxidável à prova de dedadas mantém o aço inoxidável com um aspeto novo.		Circogas: Em fornos a gás, o ventilador distribui o calor de forma rápida e uniforme por toda a cavidade do forno, evitando a transferência de sabor ao cozinhar vários pratos diferentes ao mesmo tempo. Em fornos elétricos, esta combinação completa o cozimento mais rapidamente de alimentos que estão prontos na superfície, mas que exigem mais cozimento no interior, sem mais escurecimento.
	Ventilador com elementos superiores e inferiores: Os elementos combinados com o ventilador visam fornecer calor mais uniforme, um método semelhante ao cozimento convencional, de modo que o pré-aquecimento é necessário. Mais adequado para itens que exigem métodos de cozimento lento.		Somente elementos superior e inferior: um método de cozimento tradicional mais adequado para itens individuais localizados no centro do forno. A parte superior do forno será sempre mais quente. Ideal para assados, bolos de frutas, pão, etc.
	Circulaire: A combinação do ventilador e do elemento circular em torno dele dá um método de cozimento de ar quente. Isso oferece muitos benefícios, incluindo nenhum pré-aquecimento se o tempo de cozimento for superior a 20 minutos, nenhuma transferência de sabor ao cozinhar alimentos diferentes ao mesmo tempo, menos energia e tempos de cozimento mais curtos. Bom para todos os tipos de alimentos.		ECO: A combinação da grelha, ventilador e elemento inferior é particularmente adequada para cozinhar pequenas quantidades de alimentos.

-  **Elemento de grelha** O uso de grelha dá excelentes resultados ao cozinhar carne de porções médias e pequenas, especialmente quando combinada com uma rotisseria (sempre que possível). Também é ideal para cozinhar salsichas e bacon.
-  **Ventilador com elemento de grelha:** O ventilador reduz o calor feroz da grelha, proporcionando um excelente método de grelhar vários alimentos, costeletas, bifés, salsichas, etc. dando o mesmo escurecimento e distribuição de calor, sem secar os alimentos. Os dois níveis superiores recomendados para uso e a parte inferior do forno podem ser usados para manter os itens quentes ao mesmo tempo, uma excelente facilidade ao cozinhar um café da manhã grelhado. Meia grelha (apenas porção central) é ideal para pequenas quantidades de alimentos.
-  **Circulaire com auxílio de vapor:** Proporciona umidade extra aos alimentos durante a cozedura. Excelente para assar pão. A umidade permite que a massa de pão se estique ainda mais no início da cozedura, criando uma massa arejada e de textura leve. A parte restante do processo de cozimento permite que a crosta característica se forme.
-  **Toda a porta interna de vidro:** Toda a porta interna de vidro, uma única superfície plana que é simples de manter limpa.
-  **Luzes laterais:** Duas luzes laterais opostas aumentam a visibilidade dentro do forno.
-  **Pirólítico:** Os ciclos de limpeza pirólítica podem ser selecionados conforme necessário para limpar automaticamente o interior do forno.
-  **O compartimento do forno tem 5 níveis de cozimento diferentes.**
-  **Meia grelha:** Para cozinhar rapidamente e dourar os alimentos. Os melhores resultados podem ser obtidos usando a prateleira superior para itens pequenos, as prateleiras inferiores para os maiores, como costeletas ou salsichas. Para metade do calor da grelha é gerado apenas no centro do elemento, por isso é ideal para quantidades menores.
-  **Circulaire com elementos superior e inferior:** O uso do ventilador com ambos os elementos permite que os alimentos sejam cozinhados de forma rápida e eficaz, ideal para grandes peças que exigem cozimento completo. Oferece um resultado semelhante ao da rotisseria, movendo o calor em torno do alimento, em vez de mover o próprio alimento, permitindo que qualquer tamanho ou forma seja cozida.
-  **Protecção contra o sobreaquecimento:** O sistema de segurança que desliga automaticamente a placa em caso de sobreaquecimento da unidade de controle.
-  **O vidro interior da porta:** pode ser removido com alguns movimentos rápidos para limpeza.
-  **Abertura automática:** alguns modelos têm porta de abertura automática quando o ciclo é terminado, o que é uma solução perfeita para unidades de cozinha sem alça, pois nenhuma alça é necessária. Por razões de segurança, a porta trava automaticamente quando a máquina está em uso para evitar que seja aberta inadvertidamente.
-  **Indicação de calor residual:** Depois de a placa de cerâmica de vidro ter sido desligada, o indicador de calor residual mostra qual das zonas de aquecimento ainda permanece quente. Quando a temperatura cai abaixo de 60°C, o indicador se apaga.
-  **Fechamento suave:** todos os modelos estão equipados com função avançada de fechamento suave da porta, o que permite que o dispositivo feche suave e silenciosamente.

-
- | | | | |
|--|---|---|---|
|  | Trilhos telescópicos: permitem puxar o prato e verificá-lo sem ter que removê-lo completamente do forno. |  | Comando eletrônico. Permite manter a temperatura no interior do forno com a precisão de 2-3 ° C. Isso permite cozinhar refeições que são muito sensíveis a mudanças de temperatura, como por ex. bolos, suflês, pudins. |
|  | Grelha basculante: a grelha basculante pode ser facilmente desengatada para mover o elemento de aquecimento e limpar o tejadilho do aparelho em um simples passo. |  | Queimadores ultrarrápidos: Queimadores ultrarrápidos potentes oferecem até 5kw de potência. |
|  | Limpeza a Vapor: uma função de limpeza simples que utiliza vapor para afrouxar os depósitos no compartimento do forno. |  | A capacidade indica a quantidade de espaço útil no compartimento do forno em litros. |
|  | A capacidade indica a quantidade de espaço útil no compartimento do forno em litros. |  | ... |

Benefit (TT)

Pyrolysis

Easy oven cleaning thanks to special pyrolytic function

Touch control

Easy and intuitive timer setting with a single touch

Drawer storage compartment

More space thanks to the lower drawer compartment, ideal for storing accessories or cooking utensils

True-convection

The best cooking performances guaranteed by ventilated circular flow

Multiple fans and heating elements guarantee the perfect aerodynamic heat flow, allowing homogeneous and quicker cooking inside the cavity.

Multilevel cooking

Several cooking levels allow maximum flexibility of use

Multilevel halogen light

Internal halogen lighting on different levels guarantees excellent visibility

Removable inner glass

Internal door glasses are easily removable for complete cleaning

Tangential cooling

New cooling system with tangential fan and airflow from the door to the splashback

Telescopic guides

Easy extraction and safe insertion of trays into the oven thanks to telescopic guides

Isothermic Cavity

The best cooking performance at the highest energy efficiency

Adjustable height

Cooker top flushed with the working area thanks to adjustable feet

AirFry (AIRFRY optional accessory)

Lighter and tastier food thanks to airfry basket (optional accessory)

Cold door

During any function, the external door glass is cold, avoiding any risk of burns

Pizza stone (optional accessory)

Baking with refractory stone for soft and crispy pizza and yeast products (STONE optional accessory)

BBQ (optional accessory)

Barbeque cooking directly in the oven with the double-sided grill (BBQ optional accessory)

Soft close

The door is equipped with a specific system for silent closing

Single turbine

The oven has a fan equipped with a circular heating element allowing cooking with rotating heat

Direct Steam

Steam is generated from water placed in a dedicated basin at the bottom of the cavity