

# CPF36UGGWH

Cooker size	36"
N. of cavities with energy label	1
Cavity heat source	GAS
Type of main oven	Gas with gas grill
EAN code	8017709265236



## Aesthetics



<b>Aesthetic</b>	Portofino	<b>Controls colour</b>	Stainless steel
<b>Design</b>	Flush fit	<b>No. of controls</b>	8
<b>Colour</b>	White	<b>Serigraphy colour</b>	Black
<b>Command panel finish</b>	Enamelled metal	<b>Display</b>	Touch
<b>Logo</b>	Assembled st/steel	<b>Door</b>	With frame
<b>Logo position</b>	Facia below the oven	<b>Glass type</b>	Grey
<b>Upstand</b>	Yes	<b>Handle</b>	Smeg Portofino
<b>Hob colour</b>	Stainless steel	<b>Handle Colour</b>	coloured
<b>Type of pan stands</b>	Cast Iron	<b>Storage compartment</b>	Push pull
<b>Type of control setting</b>	Control knobs	<b>Feet</b>	Stainless steel
<b>Control knobs</b>	Smeg Portofino	<b>Plinth</b>	Black

## Programs / Functions

<b>No. of cooking functions</b>	3
<b>Traditional cooking functions</b>	

 Large grill	 Base	 Fan assisted bottom
--	--	---

### Other functions

 Defrost by time
--

## Hob technical features

UR

**Total no. of cook zones 5**

Left - Gas - 2UR (dual) - 5.86 kW - 20000 BTU

Rear centre - Gas - AUX - 1.31 kW - 4500 BTU

Front centre - Gas - Rapid - 3.08 kW - 10500 BTU

Rear right - Gas - Rapid - 3.51 kW - 12000 BTU

Front right - Gas - Semi Rapid - 2.34 kW - 8000 BTU

<b>Type of gas burners</b>	Standard	<b>Gas safety valves</b>	Yes
<b>Automatic electronic ignition</b>	Yes	<b>Burner caps</b>	Matt black enamelled

## Main Oven Technical Features



<b>No. of lights</b>	2	<b>Full glass inner door</b>	Yes
<b>Fan number</b>	3	<b>Removable inner door</b>	Yes
<b>Gross volume, 1st cavity</b>	0.16 cu. ft.	<b>Total no. of door glasses</b>	3
<b>Cavity material</b>	Ever Clean enamel	<b>No. of thermo-reflective door glasses</b>	2
<b>No. of shelves</b>	5	<b>Safety Thermostat</b>	Yes
<b>Type of shelves</b>	Metal racks	<b>Cooling system</b>	Tangential
<b>Light type</b>	Halogen	<b>Usable cavity space dimensions (HxWxD)</b>	345 x 690 x 415 "
<b>Light Power</b>	40 W	<b>Temperature control</b>	Electro-mechanical
<b>Cooking time setting</b>	Start and Stop	<b>Grill type</b>	Gas
<b>Door opening</b>	Flap down	<b>Soft Close system</b>	Yes
<b>Removable door</b>	Yes		

## Options Main Oven

<b>Timer</b>	Yes	<b>Minimum Temperature</b>	120 °F
<b>End of cooking acoustic alarm</b>	Yes	<b>Maximum temperature</b>	500 °F

## Accessories included for Main Oven & Hob



<b>Cast iron wok support</b>	1	<b>Grill mesh</b>	1
<b>TOP Oven grid with back stop</b>	2	<b>Telescopic Guide rails, total Extraction</b>	1
<b>20mm deep tray</b>	1		

## Electrical Connection

<b>Plug</b>	(B) NEMA 5-15P	<b>Voltage 2 (V)</b>	120 V
<b>Electrical connection rating</b>	200 W	<b>Type of electric cable installed</b>	Yes, Single phase
<b>Current</b>	2 A		

Circuit breaker 15 A  
Voltage 120 V

Power supply cable length 47 1/4 "  
Frequency 60 Hz  
Terminal block 3 poles

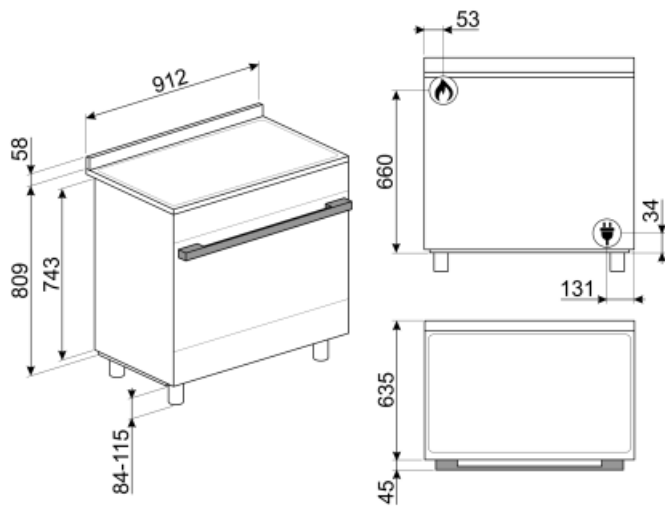

---

## Not included accessories

---



**SFLK1**  
Child lock



**BGTR9**  
Cast iron grill plate suitable for 90 cm Victoria, 60 and 90 cm Master and Sinfonia cookers



**PPR9**  
Refractory pizza stone without handles. Squared shaped stone: L64xH2,3xP37,5 cm Suitable also for gas ovens, to be put on the griddle.



**PRTX**  
Refractory pizza stone with handles. D=35cm Not suitable for microwave ovens. Suitable for gas ovens, to be put on the griddle.























**GT3T**  
Totally extractable telescopic guides



**PALPZ**  
Pizza shovel with folding handle. Dimensions L31.5 x H32.5 cm. Easy and convenient to use and store. Perfect for serving pizza, bread and savory pastries in a safe and professional way.

## Symbols glossary (TT)

 <p><b>Triple Fan Technology:</b> The oven is equipped with an exclusive three fan system, which, combined with the increased power of the motors, enables excellent cooking performance. The two large side fans distribute the air around the outer perimeter of the cavity while the smaller central fan increases ventilation by creating a vertical vortex of heat. Accordingly, the temperature within the cavity is uniform, allowing food to be cooked evenly on all five levels, like in professional kitchens.</p>	 <p><b>Heavy duty cast iron pan stands:</b> for maximum stability and strength.</p>
 <p><b>Installation in column:</b> Installation in column</p>	 <p><b>Air cooling system:</b> to ensure a safe surface temperatures.</p>
 <p><b>Defrost by time:</b> Manual defrost function. At the end of the set duration, the function stops.</p>	 <p><b>Triple glazed doors:</b> Number of glazed doors.</p>
 <p><b>Ever Clean Enamel:</b> Ever Clean enamel is applied electrostatically, corner to corner and edge to edge to prevent cracking or cracks over time. It is a particular pyrolytic enamel, resistant to acids which, in addition to being pleasantly bright, promotes greater cleaning of the oven walls, thanks to its lower porosity. It is baked at over 850 ° C and slowly polymerized at a scientifically determined rate to ensure uniform depth and strength Ever Clean enamel creates an impeccable finish both on the inside of the oven and on the trays, making the surfaces of the oven incredibly easy to maintain over time as it reduces the adhesion of fat during cooking</p>	 <p><b>Fan assisted base:</b> the mix of fan and lower heating element alone allows to finish cooking foods already cooked on the surface but not internally more quickly. This system is recommended to finish cooking foods that are already well cooked on the surface, but not internally, which therefore require a moderate higher heat. Ideal for any type of food.</p>
 <p><b>Base:</b> the heat comes only from the bottom of the cavity. The fan is not active. Ideal for sweet and savory pies, cobbler and pizzas. Designed to complete cooking and make food more crunchy This symbol in gas ovens indicates the gas burner.</p>	 <p><b>Grill:</b> Very intense heat coming only from above from a double heating element. The fan is not active. Provides excellent grilling and gratinating results. Used at the end of cooking, it gives a uniform browning to dishes.</p>
 <p><b>Gas ovens offer instantaneous heat control,</b> reduced cooking times and the ability to bake at much lower temperatures than electric ovens.</p>	 <p><b>All glass inner door:</b> All glass inner door, a single flat surface which is simple to keep clean.</p>
 <p><b>The inner door glass:</b> can be removed with a few quick movements for cleaning.</p>	 <p><b>Side lights:</b> Two opposing side lights increase visibility inside the oven.</p>
 <p><b>Automatic opening:</b> some models have Automatic opening door when the cycle is finished which is a perfect solution for handle-less kitchen units as no handle is needed. For safety reasons, the door locks automatically when the machine is in use to avoid it being opened inadvertently.</p>	 <p><b>The oven cavity has 5 different cooking levels.</b></p>

- 
-  Soft close: all models are equipped with advanced function of smooth closing of the door, which allows the device to close smoothly and quietly.
  -  Telescopic rails: allow you to pull out the dish and check it without having to remove it from the oven entirely.
  -  Ultra rapid burners: Powerful ultra rapid burners offer up to 5kw of power.
  -  4.3 inch display with LED technology, usability with knobs + 3 touch keys
  -  Knobs control

## Benefit (TT)

---

### **Gas hob**

Induction offers fast cooking and precise temperature control

Equipped with a thermocouple, the gas supply is cut off if the flame is extinguished for greater safety

### **Touch control**

Easy and intuitive timer setting with a single touch

### **Isothermic Cavity**

The best cooking performance at the highest energy efficiency

### **Triple Turbine**

The oven has three fans and two circular heating elements, allowing cooking with rotating heat

### **Tangential cooling**

New cooling system with tangential fan and airflow from the door to the splashback

### **Soft close**

The door is equipped with a specific system for silent closing

### **Multilevel halogen light**

Internal halogen lighting on different levels guarantees excellent visibility

### **Telescopic guides**

Easy extraction and safe insertion of trays into the oven thanks to telescopic guides

### **Adjustable height**

Cooker top flushed with the working area thanks to adjustable feet

### **Removable inner glass**

Internal door glasses are easily removable for complete cleaning

### **Multilevel cooking**

Several cooking levels allow maximum flexibility of use

### **Cold door**

During any function, the external door glass is cold, avoiding any risk of burns

### **AirFry (AIRFRY optional accessory)**

Lighter and tastier food thanks to airfry basket

**BBQ (optional accessory)**

Barbeque cooking directly in the oven with the double-sided grill

**Pizza stone (optional accessory)**

Baking with refractory stone for soft and crispy pizza and yeast products (STONE optional accessory)

**Push-pull storage compartment**

More space thanks to the lower push-pull compartment, ideal for storing accessories or cooking utensils