

# CPF48UGMX

Cooker size	48"
Type of main oven	Thermo-ventilated
Type of second oven	Static
EAN code	8017709259082



## Aesthetics













<b>Aesthetic Design</b>	Portofino	<b>Type of control setting</b>	Control knobs
<b>Colour</b>	Flush fit	<b>No. of controls</b>	10
<b>Finishing</b>	Stainless steel	<b>Serigraphy colour</b>	Black
<b>Logo</b>	Satin	<b>Display</b>	Touch
<b>Logo position</b>	Assembled st/steel	<b>Handle</b>	Smeg Portofino
<b>Hob colour</b>	Facia below the oven	<b>Storage compartment</b>	Door
<b>Type of pan stands</b>	Stainless steel	<b>Plinth</b>	Black
	Cast Iron		

## Programs / Functions

No. of cooking functions 9

Traditional cooking functions

 Static	 Fan assisted	 Circulaire
 Small grill	 Large grill	 Fan grill (large)
 Base	 Fan assisted bottom	 Pizza
 Rotisserie		

### Other functions

 Defrost by time

### Cleaning functions

 Vapor clean

## Programs / Functions Auxiliary Oven

Bottom element + fan



## Hob technical features

**Total no. of cook zones** 6

Left - 5.3 kW - 18000 BTU

Rear centre - 3.5 kW - 12000 BTU

Front centre - 1.31 kW - 4500 BTU

Central - 1.40 kW - 12000 BTU

Rear right - 3.5 kW - 8000 BTU

Front right - 2.34 kW - 6500 BTU

**Gas safety valves** Yes

**Burner caps**

Matt black enamelled

## Main Oven Technical Features



**No. of lights** 2

**Fan number** 3

**Gross volume, 1st cavity** 0.16 cu. ft.

**Cavity material** Ever Clean enamel

**No. of shelves** 5

**Type of shelves** Metal racks

**Light type** Halogen

**Light Power** 40 W

**Cooking time setting** Start and Stop

**Light when oven door is open** Yes

**Removable door** Yes

**Total no. of door glasses** 3

**Safety Thermostat** Yes

**Cooling system** Tangential

**Lower heating element power** 1700 W

**Upper heating element - Power** 1200 W

**Grill element** 1700 W

**Large grill - Power** 2900 W

**Circular heating element - Power** 1500 W

**Grill type** Electric

**Soft Close system** Yes

## Options Main Oven

**Timer** Yes

**End of cooking acoustic alarm** Yes

**Minimum Temperature** 120 °F

**Maximum temperature** 500 °F

## Second Oven Technical Features



<b>Fan number</b>	1	<b>Light when oven door is open</b>	Yes
<b>Gross volume, 2nd cavity</b>	1.5 cu. ft.	<b>Removable door</b>	Yes
<b>Cavity material</b>	Ever Clean enamel	<b>No. total door glasses</b>	3
<b>No. of shelves</b>	5	<b>Safety Thermostat</b>	Yes
<b>Type of shelves</b>	Metal racks	<b>Cooling system</b>	Tangential
<b>No. of lights</b>	2	<b>Lower heating element - power</b>	750 W
<b>Light type</b>	Halogen	<b>Large grill - Power</b>	2050 W
<b>Light Power</b>	40 W	<b>Circular heating element - Power</b>	1500 W

## Options Auxiliary Oven

<b>Minimum Temperature</b>	120 °F	<b>Maximum temperature</b>	450 °F
----------------------------	--------	----------------------------	--------

## Accessories included for Main Oven & Hob



<b>Cast iron wok support</b>	1	<b>40mm deep tray</b>	1
<b>TOP Oven grid with back stop</b>	2	<b>Telescopic Guide rails, total Extraction</b>	1

## Accessories included for Secondary Oven



<b>Rack with back and side stop</b>	1	<b>Grill mesh</b>	1
<b>Wide baking tray</b>	1	<b>Telescopic Guide rails, total Extraction</b>	1

## Electrical Connection

<b>Electrical connection rating</b>	8000 W	<b>Type of electric cable installed</b>	Yes, Double phase
<b>Current</b>	50 A	<b>Power supply cable length</b>	47 1/4 "
<b>Circuit breaker</b>	50 A	<b>Frequency</b>	60 Hz
<b>Voltage</b>	240/208 V	<b>Terminal block</b>	5 poles

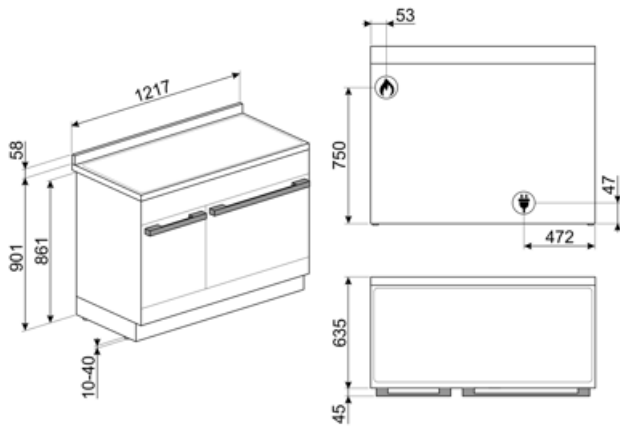

---

## Not included accessories

---

### GTT

Totally extractable telescopic guides (1 level), suitable for traditional ovens. Made in stainless steel, they guarantee stability and facilitate the smooth extraction of the trays.



### PPR9

Refractory pizza stone without handles. Squared shaped stone: L64xH2,3xP37,5 cm Suitable also for gas ovens, to be put on the griddle.



### PALPZ

Pizza shovel with folding handle. Dimensions L31.5 x H32.5 cm. Easy and convenient to use and store. Perfect for serving pizza, bread and savory pastries in a safe and professional way.

































### SFLK1

Child lock



## Symbols glossary

 <p><b>Triple Fan Technology:</b> The oven is equipped with an exclusive three fan system, which, combined with the increased power of the motors, enables excellent cooking performance. The two large side fans distribute the air around the outer perimeter of the cavity while the smaller central fan increases ventilation by creating a vertical vortex of heat. Accordingly, the temperature within the cavity is uniform, allowing food to be cooked evenly on all five levels, like in professional kitchens.</p>	 <p><b>Heavy duty cast iron pan stands:</b> for maximum stability and strength.</p>
 <p><b>Installation in column:</b> Installation in column</p>	 <p><b>Knobs control</b></p>
 <p><b>Air cooling system:</b> to ensure a safe surface temperatures.</p>	 <p><b>Defrost by time:</b> Manual defrost function. At the end of the set duration, the function stops.</p>
 <p><b>4.3 inch display with LED technology, usability with knobs + 3 touch keys</b></p>	 <p><b>Triple glazed doors:</b> Number of glazed doors.</p>
 <p><b>Ever Clean Enamel:</b> Ever Clean enamel is applied electrostatically, corner to corner and edge to edge to prevent cracking or cracks over time. It is a particular pyrolytic enamel, resistant to acids which, in addition to being pleasantly bright, promotes greater cleaning of the oven walls, thanks to its lower porosity. It is baked at over 850 ° C and slowly polymerized at a scientifically determined rate to ensure uniform depth and strength Ever Clean enamel creates an impeccable finish both on the inside of the oven and on the trays, making the surfaces of the oven incredibly easy to maintain over time as it reduces the adhesion of fat during cooking</p>	 <p><b>Fingerprint proof stainless steel:</b> Fingerprint proof stainless steel keeps stainless steel looking as good as new.</p>
 <p><b>Fan assisted base:</b> the mix of fan and lower heating element alone allows to finish cooking foods already cooked on the surface but not internally more quickly. This system is recommended to finish cooking foods that are already well cooked on the surface, but not internally, which therefore require a moderate higher heat. Ideal for any type of food.</p>	 <p><b>Fan assisted:</b> Intense and homogeneous traditional cooking, also suitable for complex recipes. The fan is active and the heat comes from below and from above at the same time. Ventilated cooking ensures a faster and more homogeneous result, leaving fragrant foods outside and moister inside. Ideal for baked pasta, biscuits, roasts and cobblers.</p>
 <p><b>Static:</b> Traditional cooking suitable for the preparation of one dish at a time. The fan is not active and the heat comes from below and from above at the same time. Static cooking is slower and more delicate, ideal in order to get well cooked and dry dishes even inside. Ideal for cooking all types of roasts, fatty meats, bread, filled cakes.</p>	 <p><b>Base:</b> the heat comes only from the bottom of the cavity. The fan is not active. Ideal for sweet and savory pies, cobblers and pizzas. Designed to complete cooking and make food more crunchy This symbol in gas ovens indicates the gas burner.</p>

-  **Circulaire:** it is the perfect function for cooking all types of dishes in a more delicate way. The heat comes from the back of the oven and is distributed quickly and evenly. The fan is active. It is also ideal for cooking on multiple levels without mixing smells and flavors.
-  **Half grill:** For rapid cooking and browning of foods. Best results can be obtained by using the top shelf for small items, the lower shelves for larger ones, such as chops or sausages. For half grill heat is generated only at the centre of the element, so is ideal for smaller quantities.
-  **Light**
-  **Rotisserie:** The rotisserie (where installed) works in combination with the grill element to brown foods to perfection.
-  **Automatic opening:** some models have Automatic opening door when the cycle is finished which is a perfect solution for handle-less kitchen units as no handle is needed. For safety reasons, the door locks automatically when the machine is in use to avoid it being opened inadvertently.
-  **Soft close:** all models are equipped with advanced function of smooth closing of the door, which allows the device to close smoothly and quietly.
-  **Electronic control:** Allows you to maintain temperature inside the oven with the precision 2-3 ° C. This enables to cook meals that are very sensitive to temperature changes, such as cakes, souffles, puddings.
-  **Vapor Clean:** a simple cleaning function using steam to loosen deposits in the oven cavity.
-  **Grill:** Very intense heat coming only from above from a double heating element. The fan is not active. Provides excellent grilling and gratinating results. Used at the end of cooking, it gives a uniform browning to dishes.
-  **Fan grill:** very intense heat coming only from above from a double heating element. The fan is active. It allows the optimal grilling of thickest meats. Ideal for large cuts of meat.
-  **Pizza function:** Specific function for cooking pizza in a pan. It allows to obtain a pizza that is soft inside and crispy outside with the topping perfectly cooked, not dry and not burnt.
-  **Side lights:** Two opposing side lights increase visibility inside the oven.
-  **5** The oven cavity has 5 different cooking levels.
-  **Telescopic rails:** allow you to pull out the dish and check it without having to remove it from the oven entirely.
-  **UR** **Ultra rapid burners:** Powerful ultra rapid burners offer up to 5kw of power.
-  **35 lt** The capacity indicates the amount of usable space in the oven cavity in litres.

---

## Benefit (TT)

---

### **Ever Clean Enamel**

Easy oven cleaning thanks to special pyrolytic enamel

### **Touch control**

Easy and intuitive timer setting with a single touch

### **Storage compartment**

More space thanks to the lower compartment, ideal for storing accessories or cooking utensils

### **True-convection**

The best cooking performances guaranteed by ventilated circular flow.

Multiple fans and heating elements guarantee the perfect aerodynamic heat flow, allowing homogeneous and quicker cooking inside the cavity.

### **Multilevel cooking**

Several cooking levels allow maximum flexibility of use

### **Multilevel halogen light**

Internal halogen lighting on different levels guarantees excellent visibility

### **Tangential cooling**

New cooling system with tangential fan and airflow from the door to the splashback

### **Telescopic guides**

Easy extraction and safe insertion of trays into the oven thanks to telescopic guides

### **Isothermic Cavity**

The best cooking performance at the highest energy efficiency

### **AirFry (AIRFRY optional accessory)**

Lighter and tastier food thanks to airfry basket

### **Cold door**

During any function, the external door glass is cold, avoiding any risk of burns

### **Pizza stone (optional accessory)**

Baking with refractory stone for soft and crispy pizza and yeast products (STONE optional accessory)

### **BBQ (optional accessory)**

Barbeque cooking directly in the oven with the double-sided grill



---

**Adjustable height**

Cooker top flushed with the working area thanks to adjustable feet

**Soft close**

The door is equipped with a specific system for silent closing

**Triple Turbine**

The oven has three fans and two circular heating elements, allowing cooking with rotating heat