

# CV102E

Product Family	Freezers
Installation	Free Standing
Category	Under counter
Reference width	Until 60 cm
Reference height	Until 100 cm
Cooling type	Static
Hinge type	Standard
Hinge position	Right
Reversible door	Yes



## Aesthetics

Aesthetic	Universale	Handle colour	White
Colour	White	Side material	Metal
Material	Steel	Side colour	White
Handle	External	Logo	Applied
Handle type	Fixed	Drawers profile color	Bianco

## Freezer compartment features

Number of drawers	1
No. of compartments with flap	2

## Other Freezer features

Ice tray shelf	Yes
----------------	-----

## Other technical features

Freezer compartment accessories	Ice cube tray	Type of compressor	Standard
Type of temperature control	Electro-mechanical	Refrigerant Quantity (g)	34 g
No. of compressors	1	Foam agent	Cyclopentane
Refrigerant gas type	R600a		

## Performance / Energy Label - Reg. 2019



<b>Annual energy consumption</b>	168 kWh/a	<b>Temperature Rise Time</b>	12 h
<b>Total net volume</b>	95 l	<b>4 star - Freezing capacity</b>	6,5 kg/24h
<b>Energy efficiency class</b>	E	<b>Climate class</b>	SN, N, ST, T
<b>Airborne acoustical noise emission class</b>	B	<b>EEl</b>	100 %
<b>Sum of the volumes of the frozen compartment(s)</b>	95 l		

## Electrical Connection

<b>Electrical connection rating</b>	70 W	<b>Frequency (Hz)</b>	50 Hz
<b>Current</b>	0,35 A	<b>Power supply cable length</b>	193 cm
<b>Voltage</b>	230 V	<b>Plug</b>	(F;E) Schuko

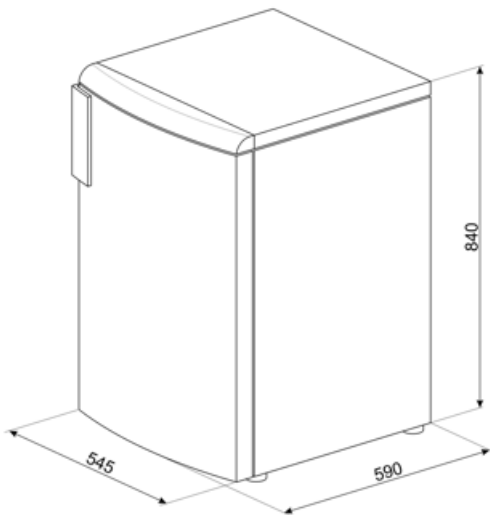

## Symbols glossary

---



4 stars freezing compartment for better food preservation.



Energy efficiency class E