

CV102E

Product Family	Freezers
Installation	Free Standing
Category	Under counter
Reference width	Until 60
Reference height	Until 100
Cooling type	Static
Hinge type	Standard
Hinge position	Right
Reversible door	Yes



Aesthetics

Aesthetic	Universal	Handle colour	White
Colour	White	Side material	Metal
Material	Steel	Side colour	White
Handle kit to be ordered separately	No	Logotipo	Logotipo aplicado
Handle	External	Cor do perfil das gavetas	Bianco
Handle type	Fixed	Display	No

Freezer compartment features

Internal light in freezer	No
Type of internal light (freezer)	No
Number of drawers	1
No. of compartments with flap	2

Other Freezer features

Warehouse availability first date	No	Ice tray shelf	Yes
-----------------------------------	----	----------------	-----

Other technical features

Freezer compartment accessories	Ice cube tray	Type of temperature control	Electro-mechanical
Fast freezing button	No	No. of compressors	1
Power on lamp	No	Refrigerant gas type	R600a

Temperature alarm lamp	No	Type of compressor	Standard
Door open alarm	No	Quantidade de refrigeração (gr.)	34 g
Temperature alarm	No	Espuma expansiva de isolamento	Ciclopentano

Etiqueta de Desempenho / Energia - Reg. 2019



Consumo de energia anual	168 kWh/a	Autonomia de conservação sem energia elétrica	12 h
Volume líquido total	95 l	4 estrelas - Capacidade de congelamento	6.5 Kg/24h
Classe de eficiência energética	E	Classe climática	SN, N, ST, T
Classe de emissão de ruído acústico aerotransportado	B	EEl	100 %
Soma dos volumes do(s) compartimento(s) congelado(s)	95 l		

Electrical Connection

Plug	(F;E) Schuko	Voltage	230 V
Electrical connection rating	70 W	Frequency (Hz)	50 Hz
Current	0.35 A	Comprimento do cabo de alimentação	193 cm

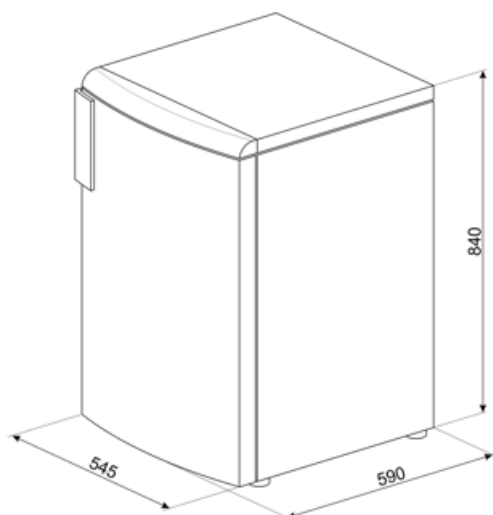

Symbols glossary



Compartimento de congelamento de 4 estrelas para uma melhor preservação dos alimentos.



Classe de eficiência energética E.