

CVI120GE



Installation	Built-in
Built-In Niche	45 cm
Reference width	Until 60
Reference height	Until 100
Defrost	Automatic
Cooling type	Fan assisted
Hinge type	Variable hinge
Hinge position	Right
Reversible door	Yes



Wine cellar compartment features



Number of fixed shelves	1
Number of removable shelves	2
No. of lights	1
Shelves material	Beech
Removable shelves on telescopic guide rails	Yes
Type of internal light	Led activated with EMOTION system
Air filter	Activated charcoal filter

Programs/Functions



Control setting	Touch control	Control lock	Yes
Controls	Inner, in the cellar compartment	Lighting forced ON	In a maximum period
Display	LED	Fan forced ON	Yes
Functions display	Temperature alarm, Temperature value	Temperature Alarm	Yes
Power on lamp	Yes	Door open alarm	Yes

Technical Features



Adjustable temperature zones	1	Number of compressors	1
		Compressor type	Low vibration compressor

Independent cooling systems	1	Refrigerant gas type	R600a
Number of door glasses	2	Refrigerant Quantity (gr)	20 g
Temperature range	5-20 °C	Foam agent	HFO
Type of temperature control	Electronic	Metal panel on the back of the fridge	Metal
Anti-UV door glass	Yes	Door opening type	With electronic opening system
Integrated heating element	Yes		

Performance / Energy Label

			
Max Capacity (bottles 0,75lt)	20	Sum of the volumes of the chill compartment(s) and the unfrozen compartment(s)	56 l
Annual energy consumption	100 kWh/a	Climatic class	SN, N, ST
Energy efficiency class	F	EI	124 %
Airborne acoustical noise emission class	C	Noise level	37 dB(A) re 1 pW
Total volume	56 l		

Electrical Connection

Electrical connection rating	40 W	Frequency (Hz)	50 Hz
Current	0.4 A	Power supply cable length	180 cm
Voltage (V)	220-240 V	Plug	(F;E) Schuko

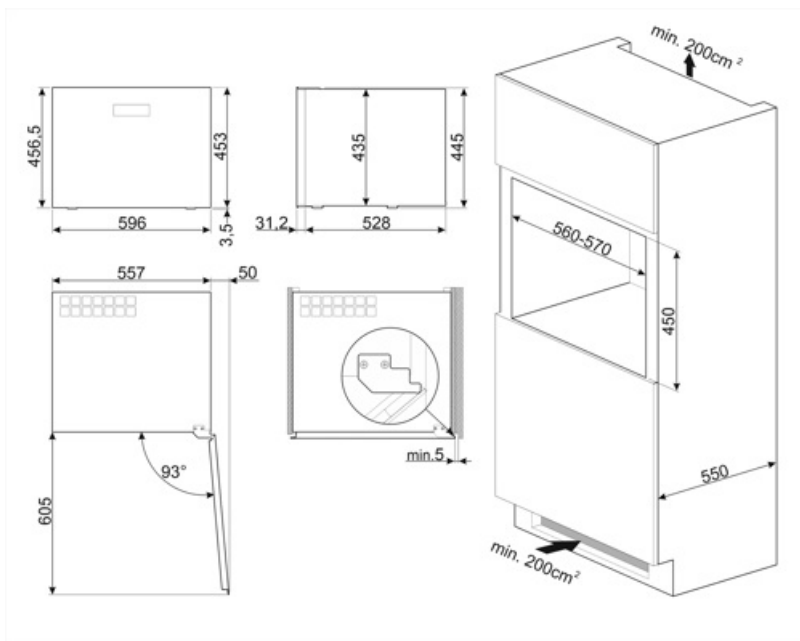









Alternative products



CVI120B3E

Colour: Black

Symbols glossary

-  The automatic defrost system works by automatically defrosting at regular intervals eliminating the need to defrost altogether.
-  Energy efficiency class F
-  E MOTION opening system: the E MOTION electronic system allows to open the appliance semi-automatically by applying pressure on the door surface.
-  LED interior lighting: is a more energy efficient and long lasting way of illuminating the interior of the appliance.
-  Touch controls: Easy to use touch controls allow the appliance to be programmed at the touch of a button.
-  A+: Energy efficiency class A+ helps to save up to 10% energy compared to class A. Maximum performance with minimum consumption is guaranteed.
-  LED display: to show programmes, functions and options selected and the time to the end of the cycle.
-  Ventilated: Forced distribution of cold air in the refrigerator compartment, which allows even temperature distribution within the fridge.
-  Built-in niche