

# CVI138RS3



<b>Product Family</b>	Wine Cooler
<b>Installation</b>	Built-in
<b>Built-In Niche</b>	82-87 cm
<b>Defrost</b>	Automatic
<b>Cooling type</b>	Fan assisted
<b>Hinge type</b>	Standard
<b>Hinge position</b>	Right



## Wine cooler compartment features



<b>Number of fixed shelves</b>	2
<b>Number of removable shelves</b>	3
<b>Shelves material</b>	Wood
<b>Removable shelves on telescopic guide rails</b>	Yes
<b>Type of internal light</b>	LED
<b>Air filter</b>	Activated charcoal filter

## Programs / Functions



<b>Control setting</b>	Touch control	<b>Control lock</b>	Yes
<b>Controls</b>	Internal, in the compartment	<b>Lighting forced ON</b>	In a maximum period
<b>Display</b>	LED	<b>Fan forced ON</b>	Yes
<b>Functions display</b>	Temperature alarm, Temperature value	<b>Temperature Alarm</b>	Yes
<b>Power on lamp</b>	Yes	<b>Door open alarm</b>	Yes

## Technical Features

<b>Adjustable temperature zones</b>	2	<b>Compressor type</b>	Low vibration compressor
<b>Independent cooling systems</b>	2	<b>Refrigerant gas type</b>	R600a
<b>Number of door glasses</b>	2	<b>Refrigerant Quantity (gr)</b>	20 g

Temperature range	5-20 °C	Foam agent	HFO
Type of temperature control	Electronic	Metal panel on the back of the fridge	Metal
Anti-UV door glass	Yes	Adjustable feet	2 Front + 2 Rear
Integrated heating element	Yes	Door opening type	With handle
Number of compressors	1		

## Performance / Energy Label NEW







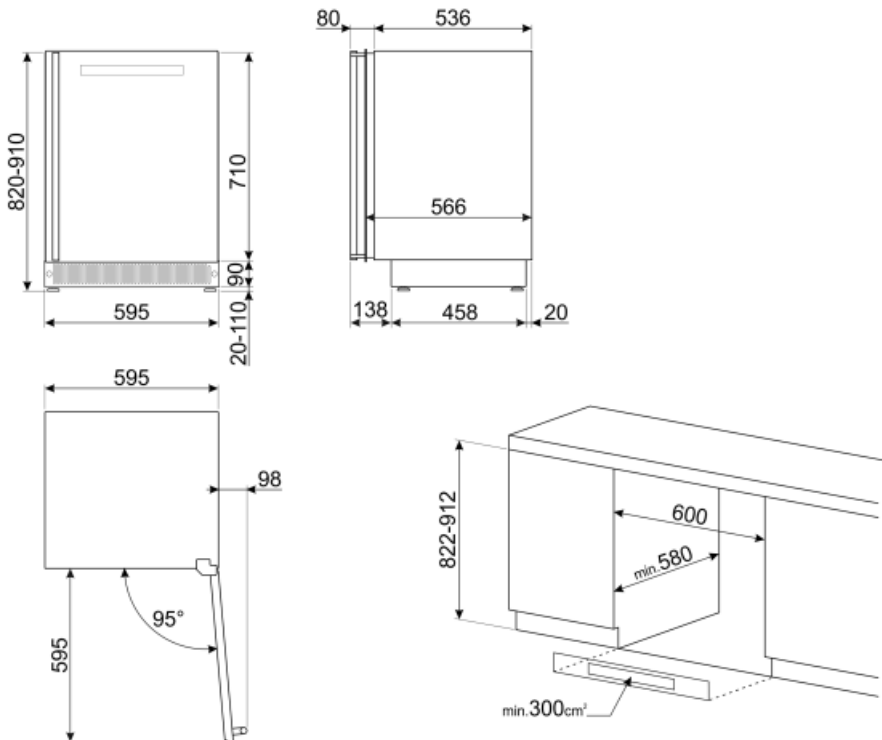

			
Max Capacity (bottles 0,75lt)	38	Sum of the volumes of the chill compartment(s) and the unfrozen compartment(s)	114 l
Annual energy consumption	140 kWh/year	Climatic class	SN, N, ST
Energy efficiency class	G	EEL	165 %
Airborne acoustical noise emission class	C	Noise level	38 dB(A) re 1pW
Total volume	114 l		

## Electrical Connection

Plug	(F;E) Schuko	Voltage (V)	220-240 V
Nominal power	40 W	Frequency (Hz)	50 Hz
Current	0,4 A	Power supply cable length	150 cm



## Symbols glossary

	The automatic defrost system works by automatically defrosting at regular intervals eliminating the need to defrost altogether.		Energy efficiency class G		A: Product drying performance, measured from A+++ to D / G depending on the product family
	Ventilated: Forced distribution of cold air in the refrigerator compartment, which allows even temperature distribution within the fridge.		LED display: to show programmes, functions and options selected and the time to the end of the cycle.		LED interior lighting: is a more energy efficient and long lasting way of illuminating the interior of the appliance.
	Built-in niche		Touch controls: Easy to use touch controls allow the appliance to be programmed at the touch of a button.		