

CVI138RWS2



Product Family	Wine Cooler
Installation	Built-in
Built-In Niche	82-87 cm
Defrost	Automatic
Cooling type	Fan assisted
Hinge type	Standard
Hinge position	Right



Wine cooler compartment features



Number of fixed shelves	2
Number of removable shelves	3
Shelves material	Wood
Removable shelves on telescopic guide rails	Yes
Type of internal light	LED
Air filter	Activated charcoal filter

Programs / Functions



Control setting	Touch control	Control lock	Yes
Controls	External, in the door	Lighting forced ON	In a maximum period
Display	LED	Fan forced ON	Yes
Functions display	Temperature alarm, Temperature value	Temperature Alarm	Yes
Power on lamp	Yes	Door open alarm	Yes

Technical Features

Adjustable temperature zones	2	Compressor type	Low vibration compressor
Independent cooling systems	2	Refrigerant gas type	R600a
Number of door glasses	2	Refrigerant Quantity (gr)	20 g
		Foam agent	Cyclopentane

Temperature range	5-20 °C	Metal panel on the back of the fridge	Metal
Type of temperature control	Electronic	Adjustable feet	2 Front + 2 Rear
Anti-UV door glass	Yes	Door opening type	With handle
Integrated heating element	Yes		
Number of compressors	1		

Performance / Energy Label







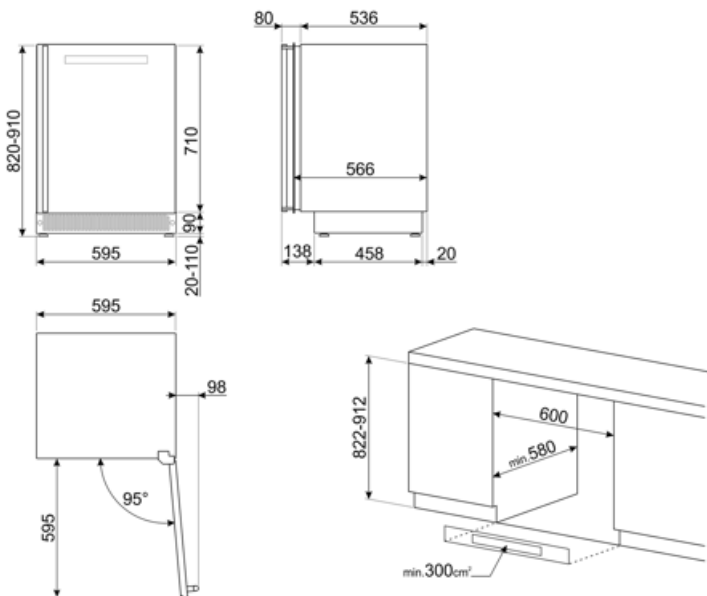



G <small>A B</small>			
Annual energy consumption	140 kWh/year	Sum of the volumes of the chill compartment(s) and the unfrozen compartment(s)	103 l
Energy efficiency class	G	Climatic class	SN, N, ST
Airborne acoustical noise emission class	C	EEL	166 %
Total volume	103 l	Noise level	40 dB(A) re 1 pW

Electrical Connection

Plug	(F;E) Schuko	Voltage (V)	220-240 V
Nominal power	40 W	Frequency (Hz)	50 Hz
Current	0,4 A	Power supply cable length	150 cm



Symbols glossary

	The automatic defrost system works by automatically defrosting at regular intervals eliminating the need to defrost altogether.		Energy efficiency class G		A: Product drying performance, measured from A+++ to D / G depending on the product family
	Ventilated: Forced distribution of cold air in the refrigerator compartment, which allows even temperature distribution within the fridge.		LED display: to show programmes, functions and options selected and the time to the end of the cycle.		LED interior lighting: is a more energy efficient and long lasting way of illuminating the interior of the appliance.
	Built-in niche		Appliances with Wi-Fi connectivity. Via SmegConnect App is possible to monitor and remotely control appliances through smartphone and tablet (iOS and Android).		Wi-Fi connectivity
	Touch controls: Easy to use touch controls allow the appliance to be programmed at the touch of a button.				

Benefit

External handle

Handle with sober and elegant aesthetics, for easy door opening

UV-protected door glass

The UV-protected door glass protects the bottles from the passage of light into the wine cooler for impeccable storage

LED lights

LED lights ensure perfect multi-level visibility inside the wine cooler

Activated charcoal air filter

The activated charcoal air filter ensures excellent quality of the air and is easy to maintain

Touch Display

Touch display for an easy and accurate temperature management inside the refrigerated compartment

Low-vibration compressor

The low-vibration compressor avoids exposing the bottles to prolonged vibrations, which could compromise the quality of the wine

Telescopic guides

Telescopic sliding guides for easy extraction of wine bottles