

CVI621RWNR3



Family	Wine Cooler
Installation	Built-in
Built-In Niche	45 cm
Defrost	Automatic
Cooling type	Fan assisted
Hinge type	Standard
Hinge position	Right
SmegConnect	Yes



Wine cellar compartment features



Number of fixed shelves	1
Number of removable shelves	2
Shelves material	Wood
Removable shelves on telescopic guide rails	Yes
Type of internal light	Led
Air filter	Activated charcoal filter

Programs/Functions



Control setting	Touch control	Lighting forced ON	In a maximum period
Controls	External, in the door	Fan forced ON	Yes
Display	LED	Temperature Alarm	Yes
Functions display	Temperature alarm, Temperature value	Door open alarm	Yes
Power on lamp	Yes	Connectivity	Wi-Fi
Control lock	Yes	UK defined Support Period	minimum 2 years with an end date of 31/12/26

Technical Features

Adjustable temperature zones	1	Number of compressors	1
Independent cooling systems	1	Compressor type	Low vibration compressor
Number of door glasses	2	Refrigerant gas type	R600a
		Refrigerant Quantity (gr)	20 g

Temperature range	5-20 °C	Foam agent	Cyclopentane
Type of temperature control	Electronic	Metal panel on the back of the fridge	Metal
Anti-UV door glass	Yes	Door opening type	With push pull system
Integrated heating element	Yes		

Performance / Energy Label NEW 2019







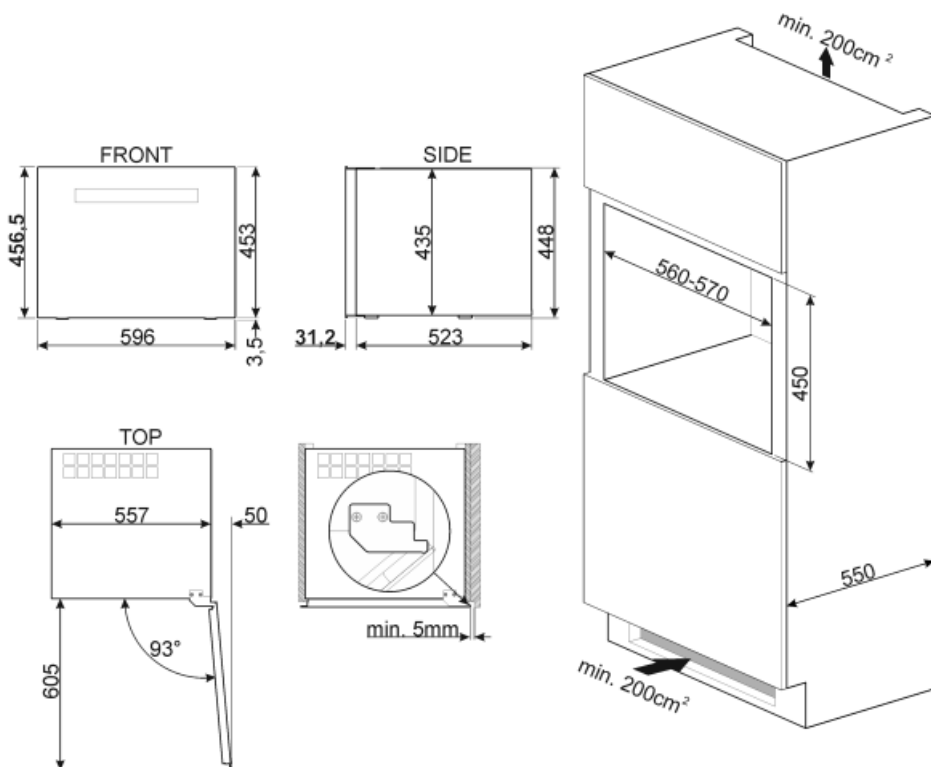



Annual energy consumption	100 kWh/a	Sum of the volumes of the chill compartment(s) and the unfrozen compartment(s)	56 l
Energy efficiency class	F	Climate class	SN, N, ST
Airborne acoustical noise emission class	C	EEl	124 %
Total net volume	56 l	Noise level	36 dB(A) re 1pW

Electrical Connection

Plug	(F;E) Schuko	Voltage (V)	220-240 V
Electrical connection rating	40 W	Frequency (Hz)	50 Hz
Current	0.4 A	Power supply cable length	150 cm



Symbols glossary (TT)

	The automatic defrost system works by automatically defrosting at regular intervals eliminating the need to defrost altogether.		LED display: to show programmes, functions and options selected and the time to the end of the cycle.
	Energy efficiency class F		A+: Energy efficiency class A+ helps to save up to 10% energy compared to class A. Maximum performance with minimum consumption is guaranteed.
	Ventilated: Forced distribution of cold air in the refrigerator compartment, which allows even temperature distribution within the fridge.		LED interior lighting: is a more energy efficient and long lasting way of illuminating the interior of the appliance.
	Built-in niche		Appliances with Wi-Fi connectivity. Via SmegConnect App is possible to monitor and remotely control appliances through smartphone and tablet (iOS and Android).
	Touch controls: Easy to use touch controls allow the appliance to be programmed at the touch of a button.		Wi-Fi connectivity