

D4152E



Product Family	Refrigerator
Installation	Built-in
Category	Double Door
Built-in niche	158
Reference width	Until 60
Reference height	100 - 160
Cooling type	Static
Defrost	Automatic
Hinge type	Sliding
Hinge position	Right
Reversible door	Yes
EAN code	8017709338534



Aesthetics



Aesthetic	Universal	Cor do perfil das prateleiras da porta	White
Colour	White	Cor do perfil das gavetas	White
Design	Flat	Cor do perfil da prateleira de vidro	White
Material	Metal sheet	Display	LED
Handle kit to be ordered separately	No	Mostrar porções	Interno (cela frigo)
Side material	Steel	Dispenser	No
Side colour	White	Water Filter	No
Logotipo	Logotipo serigrafado	HomeBar	No

Refrigerator compartment features



No. of adjustable shelves	4	Type of crisper/vegetable drawers cover	Glass
Number of fruit and vegetables drawers	1	Nº de lâmpadas	1
Type of adjustable shelves	Glass	Life Plus zone-0°C	No
Type of crisper/vegetable drawers cover	Standard	Compartimento baixa temperatura	No
Crisper Cover	Yes	Internal light in fridge	Yes
Bottle shelf	No	Type of internal light (fridge)	LED

Refrigerator Inner Door

No. of door shelves with transparent cover	1	No. of bottle shelves	1
Number of adjustable door shelves	2	Bottle shelves with wire support	No
Adjustable door shelves with wire support	No		

Other Refrigerator features

Accessories	Egg tray	Ionizer	No
Natural Plus Blu Light	No	Tecnologia de titânio	No
MultiFlow	No	Filtro de odor antibacteriano	No
Fan	No	Zona de cuidados biológicos	No

Freezer compartment features

Internal light in freezer	No
---------------------------	----

Other Freezer features

Accessories	1 ice box
-------------	-----------

Other technical features



Functions display	Fast freezing
Fast freezing button	Yes
Ligação à rede de água	No
Power on lamp	No
Temperature alarm lamp	No
Door open alarm	Yes
Temperature Alarm	No
Type of temperature control	Electronic
No. of compressors	1
Refrigerant gas type	R600a
Type of compressor	Inverter
Refrigerant Quantity (gr)	50 g
Espuma expansiva de isolamento	Ciclopentano

Etiqueta de Desempenho / Energia - Reg. 2019







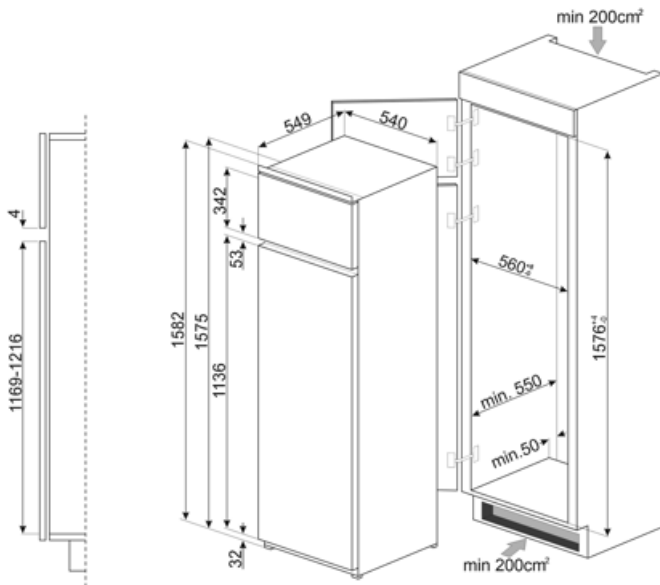

Consumo de energia anual	194 kWh/a	Airborne acoustical noise emissions	33 dB(A) re 1 pW
Classe de eficiência energética	E	Autonomia de conservação sem energia elétrica	13 h
Classe de emissão de ruído acústico aerotransportado	B	4 estrelas - Capacidade de congelamento	6.3 Kg/24h
Volume líquido total	249 l	Classe climática	SN, N, ST, T
Soma dos volumes do(s) compartimento(s) congelado(s)	50 l	EI	100 %
Soma dos volumes do(s) compartimento(s) refrigerado(s) e do(s) compartimento(s) não congelado(s)	199 l		

Electrical Connection

Plug	(F;E) Schuko	Voltage (V)	230-240 V
Electrical connection rating	200 W	Frequency (Hz)	50 Hz
Current	1,5 A	Power supply cable length	240 cm



Symbols glossary

- | | | | |
|--|---|---|---|
|  | O sistema de descongelamento automático funciona descongelando automaticamente em intervalos regulares, eliminando a necessidade de descongelar completamente. |  | Display LED: para mostrar os programas, funções e opções selecionadas e o tempo até ao final do ciclo. |
|  | CONGELAMENTO RÁPIDO: A função de congelamento rápido reduz a temperatura do compartimento quando ativado algumas horas antes do uso. |  | Iluminação interior LED: é uma forma mais eficiente em termos energéticos e duradoura de iluminar o interior do aparelho. |
|  | Tecnologia do inversor: A evolução dos secadores Smeg para modelos mais inteligentes e ambientalmente sustentáveis levou à escolha do uso da tecnologia do inversor com bombas de calor, o que reduz significativamente o consumo de energia. |  | Nicho incorporado |
|  | Classe de eficiência energética E. | | |

Benefit (TT)

Refrigerant gas R600a

Environmentally friendly R600a refrigerant gas contributes to rapid cooling with lower energy consumption

Refrigerator Internal lighting

Interior lighting for perfect visibility of shelves in the refrigerator compartment

Fruit and vegetable drawer

The fruit and vegetable drawer ensures the best storage conditions for fresh food, avoiding any contamination

Inverter compressor

Inverter compressor reduces noise and vibration levels for a quiet and comfortable kitchen environment

Inverter compressor technology offers significant advantages for refrigeration systems, improving both performance and efficiency. Better temperature control ensures a more stable and constant indoor environment, preserving the freshness of food. This technology also results in reduced energy consumption, as the compressor adjusts its speed according to cooling needs.

Internal display

Internal display for targeted temperature control and a clean, minimalist design