

# DOSF6300X

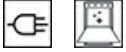

<b>Category</b>	Double in column
<b>Product Family</b>	Oven
<b>Power supply</b>	Electric
<b>Heat source</b>	ELECTRICITY
<b>Heat source second cavity</b>	ELECTRICITY
<b>Cooking method</b>	Thermo-ventilated
<b>Cooking Method Secondary Oven</b>	Static
<b>Cleaning system</b>	Ever Clean enamel
<b>EAN code</b>	8017709273583



## Aesthetics

<b>Aesthetic</b>	Classica	<b>Serigraphy type</b>	Symbols
<b>Colour</b>	Stainless steel	<b>Door</b>	With 2 horizontal strips
<b>Finishing</b>	Fingerproof	<b>Handle</b>	Classic
<b>Design</b>	Flat	<b>Handle Colour</b>	Inox
<b>Material</b>	Stainless steel	<b>Logo</b>	Embossed
<b>Type of steel</b>	Brushed	<b>Control knobs</b>	Classic
<b>Glass Type</b>	Eclipse	<b>Controls colour</b>	Steel effect
<b>Serigraphy colour</b>	Black		

## Programs / Functions main oven

**No. of cooking functions** 4  
**Traditional cooking functions**



Circulaire



Eco



Large grill



Fan grill (large)

## Programs / Functions auxiliary oven

**No. of functions Secondary oven** 4

## Traditional cooking functions, cavity 2



Static



Eco



Small grill



Large grill

## Controls



<b>Display name</b>	DigiScreen	<b>Control setting</b>	Knobs & touch buttons
<b>Display technology</b>	LED	<b>No. of controls</b>	4

## Options



<b>Time-setting options</b>	Delay start and automatic end cooking	<b>Timer</b>	1
<b>Minute minder</b>	Yes	<b>Rapid pre-heating</b>	Yes

## Options Auxiliary Oven

<b>Time-setting options</b>	No delay options
-----------------------------	------------------

## Technical Features



<b>Capacity (Lt)</b>	68 l	<b>Door opening type</b>	Standard opening
<b>Minimum Temperature</b>	50 °C	<b>Door</b>	Temperate door
<b>Maximum temperature</b>	250 °C	<b>Removable door</b>	Yes
<b>No. of shelves</b>	5	<b>Full glass inner door</b>	Yes
<b>N. of fans</b>	1	<b>Removable inner door</b>	Yes
<b>No. of lights</b>	1	<b>Total no. of door glasses</b>	3
<b>Light type</b>	Halogen	<b>Cooling system</b>	Tangential
<b>User-replaceable light</b>	Yes	<b>Cooling duct</b>	Double
<b>Light Power</b>	40 W	<b>Speed Reduction</b>	Yes
<b>Grill element - power</b>	1800 W	<b>Cooling System</b>	
<b>Circular heating element - Power</b>	2700 W	<b>Usable cavity space dimensions (HxWxD)</b>	360x444x425 mm
<b>Heating suspended when door is opened</b>	Yes	<b>Temperature control</b>	Electro-mechanical
		<b>Cavity material</b>	Ever clean Enamel

## Second Oven Technical Features



Minimum Temperature	50 °C
Maximum temperature	270 °C
No. of shelves	2
Tilting grill	Yes
No. of lights	1
Light type	Halogen
Light Power	40 W
Bottom heating element power	1200 W
Upper heating element - Power	1000 W

Grill element - power	1700 W
Large grill - Power	2700 W
Removable door	Yes
Full glass inner door	Yes
Removable inner door	Yes
No. of total door glasses	3
No. of thermoreflecting door glasses	1
Usable cavity space dimensions (HxWxD)	169x440x443 mm

## Performance / Energy Label



Energy efficiency class	A
Net volume of the cavity	70 l
Energy consumption in forced air convection	2,88 MJ
Energy consumption per cycle in fan-forced convection	0,80 kWh

Number of cavities	2
Energy efficiency index	95,2 %
Energy Efficiency Index, second cavity	120 %

## Performance /Energy Label - Second Cavity



Energy efficiency class, second cavity	B
Energy efficiency class, second cavity	B
Energy consumption per cycle in conventional mode, second cavity	0,84 kWh
Consumo di energia per ciclo in convezione naturale, seconda cavità	3,02 MJ

Net volume of the second cavity	35 l
Gross volume of second cavity	41 l
Cavity type EN 50304 second oven	medium

## Accessories included

Rack with back and side stop	2	Insert gird	2
Enamelled deep tray (40mm)	2		

## Electrical Connection

Voltage	220-240 V	Voltage 2	380-415 V
---------	-----------	-----------	-----------

Plug	Not present	Frequency (Hz)	50/60 Hz
Current	21 A	Power supply cable length	150 cm
Nominal power	4800 W		

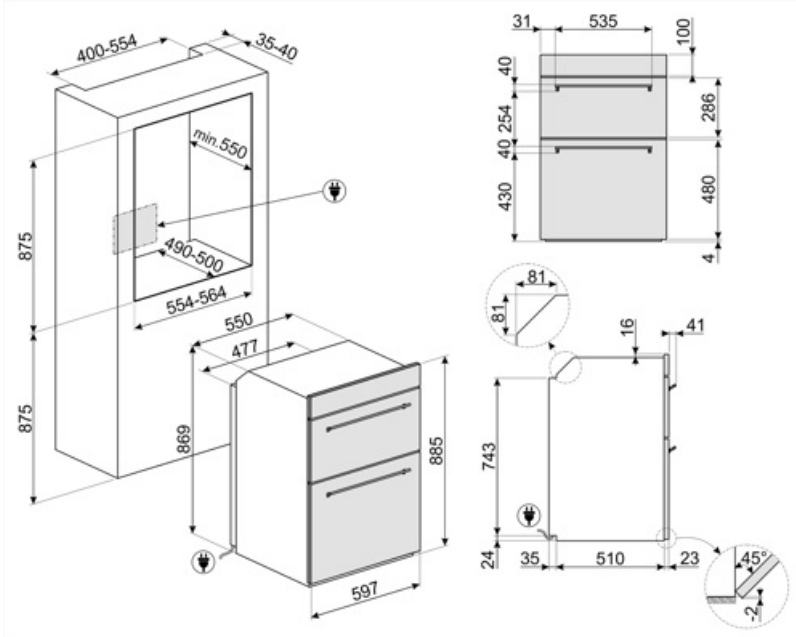

---

## Compatible Accessories

---

### GTP

Partially extractable telescopic guides (1 level), suitable for traditional ovens. Made in stainless steel, they guarantee stability and facilitate the smooth extraction of the trays.





























### GTT

Totally extractable telescopic guides (1 level), suitable for traditional ovens. Made in stainless steel, they guarantee stability and facilitate the smooth extraction of the trays.



## Symbols glossary

 Energy efficiency class A	 Air cooling system: to ensure a safe surface temperatures.
 B: Product energy rating, measured from A+++ to D / G depending on the product family.	 Triple glazed doors: Number of glazed doors.
 Electric	 Ever Clean Enamel: Ever Clean enamel is applied electrostatically, corner to corner and edge to edge to prevent cracking or cracks over time. It is a particular pyrolytic enamel, resistant to acids which, in addition to being pleasantly bright, promotes greater cleaning of the oven walls, thanks to its lower porosity. It is baked at over 850 °C and slowly polymerized at a scientifically determined rate to ensure uniform depth and strength. Ever Clean enamel creates an impeccable finish both on the inside of the oven and on the trays, making the surfaces of the oven incredibly easy to maintain over time as it reduces the adhesion of fat during cooking.
 Fingerprint proof stainless steel: Fingerprint proof stainless steel keeps stainless steel looking as good as new.	 Static: Traditional cooking suitable for the preparation of one dish at a time. The fan is not active and the heat comes from below and from above at the same time. Static cooking is slower and more delicate, ideal in order to get well cooked and dry dishes even inside. Ideal for cooking all types of roasts, fatty meats, bread, filled cakes.
 Circulaire: it is the perfect function for cooking all types of dishes in a more delicate way. The heat comes from the back of the oven and is distributed quickly and evenly. The fan is active. It is also ideal for cooking on multiple levels without mixing smells and flavors.	 ECO: low energy consumption cooking: this function is particularly suitable for cooking on a single shelf with low energy consumption. It is recommended for all types of food except those that can generate a lot of moisture (for example vegetables). To achieve maximum energy savings and reduce time, it is recommended to put the food in the oven without preheating the cooking compartment.
 ECO: low energy consumption cooking: this function is particularly suitable for cooking on a single shelf with low energy consumption. It is recommended for all types of food except those that can generate a lot of moisture (for example vegetables). To achieve maximum energy savings and reduce time, it is recommended to put the food in the oven without preheating the cooking compartment.	 Grill: Very intense heat coming only from above from a double heating element. The fan is not active. Provides excellent grilling and gratinating results. Used at the end of cooking, it gives a uniform browning to dishes.
 Half grill: For rapid cooking and browning of foods. Best results can be obtained by using the top shelf for small items, the lower shelves for larger ones, such as chops or sausages. For half grill heat is generated only at the centre of the element, so is ideal for smaller quantities.	 Fan grill: very intense heat coming only from above from a double heating element. The fan is active. It allows the optimal grilling of thickest meats. Ideal for large cuts of meat.

- 
- |  |   |   |   |
|--|---|---|---|
|  | All glass inner door: All glass inner door, a single flat surface which is simple to keep clean.  |  | The inner door glass: can be removed with a few quick movements for cleaning.   |
|  | Side lights: Two opposing side lights increase visibility inside the oven.  |  | Rapid preheating: cooking is preceded by the preheating phase which allows the cooking compartment to reach the set temperature. This option reduces the time by up to 50%. |
|  | The oven cavity has 2 different cooking levels.   |  | The oven cavity has 5 different cooking levels.   |
|  | Tilting grill: the tilting grill can be easily unhooked to move the heating element and clean the roof of the appliance in one simple step. |  | The capacity indicates the amount of usable space in the oven cavity in litres.   |
|  | The capacity indicates the amount of usable space in the oven cavity in litres.   |  | The capacity indicates the amount of usable space in the oven cavity in litres.   |
|  | The capacity indicates the amount of usable space in the oven cavity in litres.   |  | 4.3 inch display with LED technology, usability with knobs + 3 touch keys   |

---

## Benefit (TT)

---

### **Rapid pre-heating**

Reduction in cooking cavity heating time by up to 50%