

DOSF6390X



Category	60cm Double Ovens (Built-in Column)
Product Family	Oven
Power supply	Electric
Heat source	Electric
Heat source second cavity	Electric
Cooking method	Thermo-ventilated
Cooking Method Secondary Oven	Static
EAN code	8017709214203



Aesthetics

Aesthetics	Classic	Serigraphy type	Symbols
Colour	Stainless steel	Door	With 2 horizontal strips
Finishing	Fingerproof	Handle	Classic
Design	Flat	Handle Colour	Stainless steel
Material	Stainless steel	Logo	Embossed
Type of steel	Brushed	Control knobs	Classic
Glass Type	Eclipse	Controls colour	Steel effect
Serigraphy colour	Black		

Programs / Functions

No. of cooking functions	9
Automatic programmes	20
Traditional cooking functions	



Static



Fan assisted



Circulaire



Turbo (circulaire + bottom + upper + fan)



ECO



Large grill



Fan grill (large)



Base



Fan assisted base

Other functions



Defrost by time



Defrost by weight



Proving



Sabbath

Cleaning functions



Vapor Clean

Programs / Functions Auxiliary Oven

No. of functions Secondary oven 4

Traditional cooking functions, cavity 2



Static



ECO



Small grill



Large grill

Controls

Display technology	LCD	No. of controls	4
Control setting	Control knobs		

Options



Time-setting options	Delay start and automatic end cooking	Controls Lock / Child Safety	Yes
Minute minder	Yes	Showroom demo option	Yes

Options Auxiliary Oven

Time-setting options	No delay options
-----------------------------	------------------

Technical Features



Capacity (Lt)	68 l	Heating suspended when door is opened	Yes
Minimum Temperature	30 °C	Door	Fresh Touch
Maximum temperature	280 °C	Removable door	Yes
Shelf positions	5	Full glass inner door	Yes
No. of lights	1	Removable inner door	Yes
Light type	Halogen	Total no. of door glasses	3
Light power	40 W		

Light when door is opened	Yes	Cooling system	Tangential
Lower heating element power	1200 W	Cooling duct	Double
Upper heating element - Power	1000 W	Speed Reduction Cooling System	Yes
Grill element - power	1700 W	Usable cavity space dimensions (HxWxD)	316x444x425 mm
Large grill - Power	2700 W	Temperature control	Electro-mechanical
Circular heating element - Power	2000 W	Cavity material	Easy clean enamel

Second Oven Technical Features



Minimum Temperature	50 °C	Grill element - power	1700 W
Maximum temperature	270 °C	Large grill - Power	2700 W
Shelf positions	2	Removable door	Yes
Tilting grill	Yes	Full glass inner door	Yes
No. of lights	1	Removable inner door	Yes
Light type	Halogen	No. of total door glasses	3
Light power	40 W	No. of thermoreflecting door glasses	1
Bottom heating element power	1200 W	Usable cavity space dimensions (HxWxD)	169x440x443 mm
Upper heating element - Power	1000 W		

Performance / Energy Label



Energy efficiency class	A	Energy consumption per cycle in fan-forced convection	0,80 kWh
Net volume of the cavity	70 litres	Number of cavities	2
Energy consumption per cycle in conventional mode	0,99 kWh	Energy efficiency index	95,2 %
Energy consumption in conventional mode	3,56 MJ	Energy Efficiency Index, second cavity	105,7 %
Energy consumption in forced air convection	2,88 MJ		

Performance /Energy Label - Second Cavity



Energy efficiency class, second cavity	A	Net volume of the second cavity	35 litres
Energy efficiency class, second cavity	A	Gross volume of second cavity	41 l
Energy consumption per cycle in conventional mode, second cavity	0,74 kWh	Cavity type EN 50304 second oven	small

Consumo di energia per ciclo in convezione naturale, seconda cavità 2,66 MJ

Accessories Included

Chrome shelf with back and side stop 2
Extra deep enamelled tray (40mm) 2

Grill mesh 2
Catalytic Panels Yes

Electrical Connection

Voltage 220-240 V
Plug No
Current 26 A
Nominal power (W) 5900 W

Voltage 2 (V) 380-415 V
Frequency (Hz) 50/60 Hz
Power supply cable length 150 cm

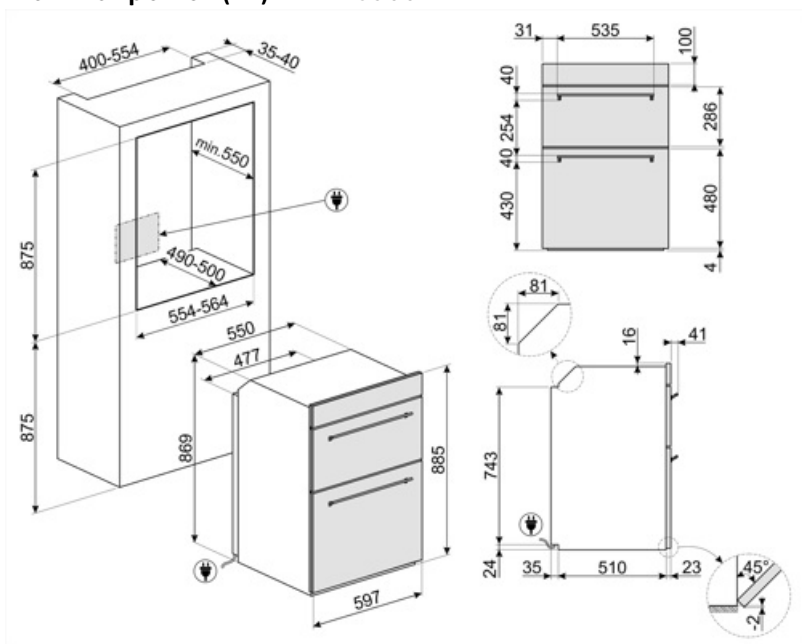

Compatible Accessories

GTP

Partially extractable telescopic guides (1 level) Extraction: 300 mm Material: Stainless steel AISI 430 polished





















GTT

Totally extractable telescopic guides (1 level) Extraction: 433 mm Material: Stainless steel AISI 430 polished





Symbols glossary

 <p>Child lock: some models are fitted with a device to lock the programme/cycle so it cannot be accidentally changed.</p>	 <p>A: Product drying performance, measured from A+++ to D / G depending on the product family</p>
 <p>Air cooling system: to ensure a safe surface temperatures.</p>	 <p>Defrost by time: with this function the time of thawing of foods are determined automatically.</p>
 <p>Defrost by weight: With this function the defrosting time is determined</p>	 <p>Triple glazed doors: Number of glazed doors.</p>
 <p>Electric</p>	 <p>Enamel interior: The enamel interior of all Smeg ovens have a special antacid lining which helps keep the interior clean by reducing the amount of cooking grease adhering to it.</p>
 <p>Fingerprint proof stainless steel: Fingerprint proof stainless steel keeps stainless steel looking as good as new.</p>	 <p>Fresh Touch: Most of Smeg ovens have a "cool door." Thanks to the combination of tangential cooling and internal heat-reflecting glasses, the temperature on the outer surface of the door is maintained below 50° C. In addition to providing safety, this system protects the sides of the furniture from overheating by the oven.</p>
 <p>Fan assisted base: the mix of fan and lower heating element alone allows to finish cooking foods already cooked on the surface but not internally more quickly. This system is recommended to finish cooking foods that are already well cooked on the surface, but not internally, which therefore require a moderate higher heat. Ideal for any type of food.</p>	 <p>Fan with upper and lower elements: The elements combined with the fan aim to provide more uniform heat, a similar method to conventional cooking, so pre-heat is required. Most suitable for items requiring slow cooking methods.</p>
 <p>Upper and lower element only: a traditional cooking method best suited for single items located in the centre of the oven. the top pf the oven will always be hottest. Ideal for roast, fruit cakes, bread etc.</p>	 <p>Lower heating element only: This function is ideal for foods that require extra base temperature without browning, e.g. pastry dishes, pizza. Also suitable for slow cooking of stews and casseroles.</p>
 <p>Circulaire: The combination of the fan and circular element around it gives a hot air cooking method. This provides many benefits including no preheat if cook time is more than 20 minutes, no flavour transfer when cooking different foods at the same time, less energy, and shorter cook times. Good for all types of food.</p>	 <p>ECO: The combination of the grill, fan and lower element is particularly suitable for cooking small quantities of food.</p>
 <p>ECO: The combination of the grill, fan and lower element is particularly suitable for cooking small quantities of food.</p>	 <p>Grill element: Using of grill gives excellent results when cooking meat of medium and small portions, especially when combined with a rotisserie (where possible). Also ideal for cooking sausages and bacon.</p>

- 

Half grill: For rapid cooking and browning of foods. Best results can be obtained by using the top shelf for small items, the lower shelves for larger ones, such as chops or sausages. For half grill heat is generated only at the centre of the element, so is ideal for smaller quantities.



Fan with grill element: The fan reduces the fierce heat from the grill, providing an excellent method of grilling various foods, chops, steaks, sausages etc. giving even browning and heat distribution, without drying out the food. The top two levels recommended for use, and the lower part of the oven can be used to keep items warm at the same time, an excellent facility when cooking a grilled breakfast. Half grill (centre portion only) is ideal for small quantities of food.
- 

Circulaire with upper and lower elements: The use of the fan with both elements allows food to be cooked quickly and effectively, ideal for large joints that require thorough cooking. It offers a similar result to rotisserie, moving the heat around the food, instead of moving the food itself, enabling any size or shape to be cooked.



All glass inner door: All glass inner door, a single flat surface which is simple to keep clean.
- 

The inner door glass: can be removed with a few quick movements for cleaning.



Side lights: Two opposing side lights increase visibility inside the oven.
- 

ECO-logic: option allows you to restrict the power limit of the appliance real energy saving.



Air at 40°C provides the perfect environment for proving yeast type dough mixes. Simply select the function and place dough in the cavity for allotted
- 

Sabbath: This function allows you to cook food whilst respecting the provisions of the Jewish day of rest.



The oven cavity has 2 different cooking levels.
- 

The oven cavity has 5 different cooking levels.



Tilting grill: the tilting grill can be easily unhooked to move the heating element and clean the roof of the appliance in one simple step.
- 

Vapor Clean: a simple cleaning function using steam to loosen deposits in the oven cavity.



The capacity indicates the amount of usable space in the oven cavity in litres.
- 

The capacity indicates the amount of usable space in the oven cavity in litres.



The capacity indicates the amount of usable space in the oven cavity in litres.
- 

The capacity indicates the amount of usable space in the oven cavity in litres.

Benefit

Removable internal glass

Easy cleaning of the oven door thanks to the removable glass

Ever Clean Enamel Interior

Cleaning made easy thanks to the special antacid lining

Ever Clean enamel is electrostatically applied from corner to corner and edge to edge to prevent cracking and cracking over time.

It is an acid-resistant enamel that, in addition to being aesthetically pleasing, promotes greater cleaning of the oven walls due to its lower porosity.

To ensure uniform depth and strength, it is baked at temperatures above 850 ° C and slowly polymerized at a scientifically determined rate.

Ever Clean enamel creates an impeccable finish both inside the oven and on the trays, making the oven surfaces incredibly easy to maintain over time by reducing fat adhesion during cooking.