

DWAFI6D15PO



Product Family	Dishwashers
Commercial width	60 cm
Commercial height	86 cm
Installation	Fully-integrated built-in
Kitchen panel	Not supplied
N° baskets	3, FlexiDuo
Motor	Single phase
EAN code	8017709220020



Programs / Functions



N. of programmes	5+5 quick programmes	ECO Quick	Yes
Washing temperatures	38, 45, 50, 65, 70 °C	Daily Quick	Yes
Soak	Yes	Normal Quick	Yes
Rapid 27'	Yes	Auto 60-70	Yes
ECO	Yes	Strong and fast	Yes
Ultraclean	Yes	Normal ECO	Yes

Options



Enersave option	Yes	Options for tabs FlexiTabs	Yes
Delay timer option	Up to 24 hours	Quick Time option	Yes
1/2 load FlexiZone option	Yes		

Baskets



Basket colour	Grey	Largest loadable dish in upper basket	18,0 cm
Basket components colour	Grey	Lower Basket	With completely foldable racks and glass holder
Handle	In plastic with stainless steel insert on upper and lower basket	Lower basket with anti-drip inserts	Yes

Upper Basket	With foldable central racks and glass holder	Largest loadable dish in lower basket	35,0 cm
Height adjustment of the upper basket	On three levels	Cutlery basket	13 place settings sliding
Upper basket with EasyGlide System	Yes		

Technical Features



Width (mm)	598 mm	Drying system	Natural condenser drying, with EnerSave automatic door opening system at the end of the cycle
Depth (mm)	550 mm	Steam protection	In plastic
Display type	LED display (3 digit)	Child safety system (door lock)	Yes
Product Height (mm)	858 mm	Internal light	With White led
Controls	Electronic	Push-pull opening system without handle	Yes
Display	Delayed start	Tube material	Stainless steel
Programme graphics	Symbols	Filter	Stainless steel
Salt light indicator	Light	Concealed heating element	Yes
Rinse aid indicator	Light	Hinges	Self balancing with variable hinges
Progress indicator	Yes	Min. and max. frontal panel weight	2 - 8 kg
End of cycle indicator	ActiveLight	Min. and max plinth height	100 - 228 mm
Washing system	Planetarium	Adjustable feet	7cm, from 860 to 930 mm
Third spray arm	Single	Insulation level	Top
Water softener	With electronic setting	Additional gaskets	Yes, with stainless steel plate
Turbidity sensor Aquatest	Yes	Back cover	Yes
Flood protection system	Total Acquastop	Depth of dishwasher with open door (mm)	1146
Water supply	Single; cold/hot water max. 60°C - energysave with hot water up to 35%	Back feet adjustable from front	Yes
Max water hardness	100°fH;58°dH		

Electrical Connection

Plug	(I) Australia	Frequency (Hz)	50 Hz
Connected power	1800 W	Type of connection	Single-phase
Current	10 A	Power supply cable length	140 cm
Voltage	220-240 V		

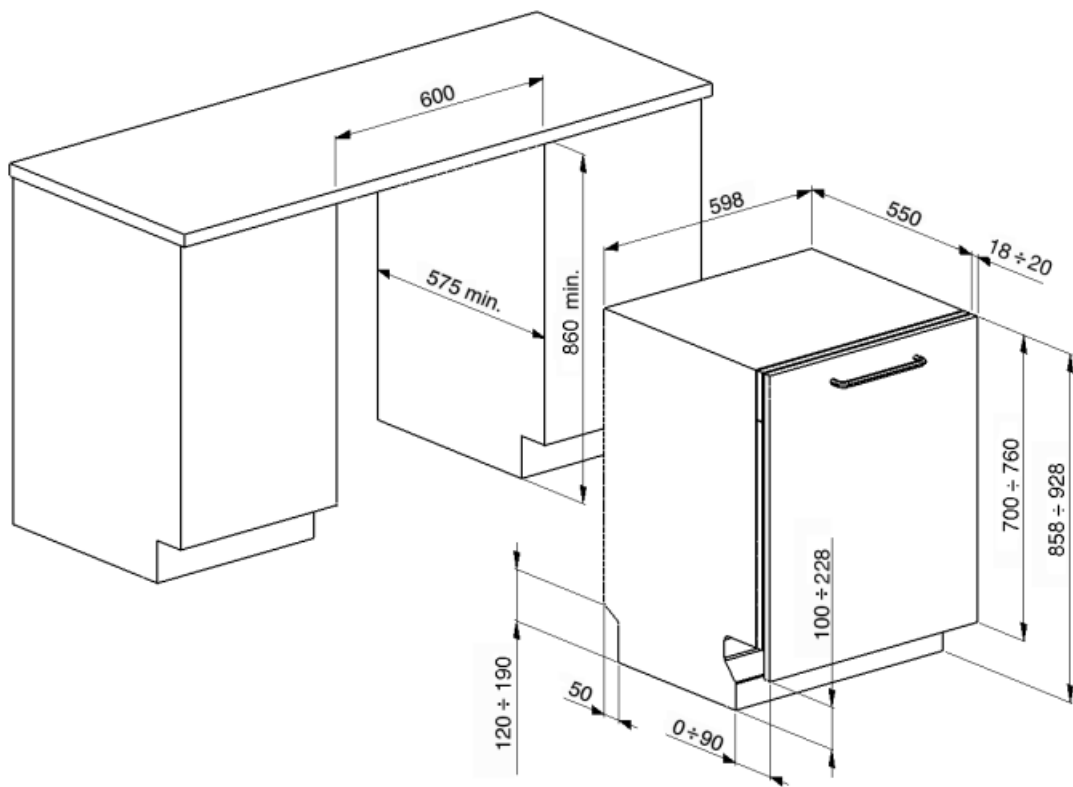

Not included accessories

KITPL60N



Toekick Kit in Black colour with adjustable height and deepness. Can be installed over all the fully integrated and underbench models with variable fulcrum or flexifit hinges.

KIT86PORTX



stainless steel panel with Portofino handle. Can be fitted on the fully integrated dishwashers H86 with no Flexifit hinges. It is not possible to install it on the models with stainless steel panel

KIT86PORTAN



Anthracite panel with Portofino handle. Can be fitted on the fully integrated dishwashers H86 with no Flexifit hinges. It is not possible to install it on the models with stainless steel panel

KITPLV2



Kit extension for dishwasher and washing machine: lenght mt. 2

KITPL60X



Toekick Kit in Stainless Steel with adjustable height and deepness. Can be fitted over all the fully integrated and underbench models with variable fulcrum or flexifit hinges.

KITPL60B



Toekick Kit in White colour with adjustable height and deepness. Can be installed over all the fully integrated and underbench models with variable fulcrum or flexifit hinges.

KIT86PORTWH







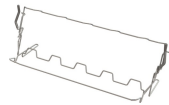

















white panel with Portofino handle. Can be fitted on the fully integrated dishwashers H86 with no Flexifit hinges. It is not possible to install it on the models with stainless steel panel

KITGH



Kit glass holder. It has to be fitted on the first basket but only if there are foldable racks

Symbols glossary (TT)

	<p>Activelight is an led light which projects a red spot onto the floor beneath the dishwasher when the appliance is in use.</p>		<p>Aquatest measures the clarity of the water during an auto program, and automatically ensures the minimum consumption of water and energy.</p>
	<p>Anti-drip: Some models of dishwashers are equipped with special polymer nozzles anti-drip, that improve the process of drying.</p>		<p>Child lock: some models are fitted with a device to lock the programme/cycle so it cannot be accidentally changed.</p>
	<p>COMM_HEIGHT_86_72dpi</p>		<p>Delay Timer: The delay timer can postpone the start of the program by up to 24 hours.</p>
	<p>EasyGlide: Convenient EasyGlide system for easy unloading of the appliance that allows reaching maximum flexibility of load of the machine.</p>		<p>FlexiDuo: The FlexiDuo 3rd cutlery basket allows you to arrange cutlery or small cups, ladles, or bulky utensils however you like: it consists of two separate and moveable modules.</p>
	<p>Flexitabs: Flexitabs adjusts the wash cycle to give the best possible results regardless of the type of detergent used.</p>		<p>FlexiZone: The 1/2 load flexizone allows you to wash a reduced load saving energy, water and time and there are no restrictions on where the items are placed.</p>
	<p>Noise Level: Excellent insulation and special devices keep noise to a minimum.</p>		<p>Automatic opening: some models have Automatic opening door when the cycle is finished which is a perfect solution for handle-less kitchen units as no handle is needed. For safety reasons, the door locks automatically when the machine is in use to avoid it being opened inadvertently.</p>
	<p>PLANETARIUM_WASHING_SYSTEM_72dpi</p>		<p>Auto 60° - 70°: The auto program regulates the length of a cycle depending on the need for a pre-wash and the number of rinses required.</p>
	<p>Daily Quick: The daily program is suitable for quick daily washing of dishes.</p>		<p>Eco: Eco, this economic wash programme uses a low amount of water and energy in order to provide the most environmentally friendly cleaning option.</p>
	<p>Eco: Eco, this economic wash programme uses a low amount of water and energy in order to provide the most environmentally friendly cleaning option.</p>		<p>Normal Quick: Program Normal Quick is suitable for quick washing of mixed dishes, for everyday use.</p>
	<p>Soak programme: The soak programme provides a rinse to prevent dirt from drying.</p>		<p>Strong&Fast: This special programme takes less than 1 hour to eliminate the most stubborn dirt and dried on residues.</p>
	<p>The symbols show the number of plate settings of the dishwasher.</p>		<p>Total Acquastop: In addition to the partial Acquastop protection present in all Smeg dishwashers, some models have an electronic device fitted to the water intake hose, which monitors water levels in the machine, detects leaks in the hose and switches off the water supply immediately when necessary.</p>



System WaterSave ensures the best washing results with minimal water consumption depending on the model of dishwasher.