

FAB10HLRD5



Product Family	Refrigerator
Installation	Free standing
Category	One Door
Reference width	Until 60
Reference height	Until 100
Cooling type	Static
Defrost	Automatic
Hinge type	Standard
Hinge position	Left
EAN code	8017709298746



Aesthetics

Aesthetic	50's Style	Handle type	Fixed
Colour	Red	Handle colour	Chrome
Finishing	Glossy	Logo colour	Chrome
Design	Rounded	Side material	Steel
Material	Heat-moulded	Side colour	Red
Handle	External	Logo	Applied

Refrigerator compartment features



No. of adjustable shelves	2	Internal light in fridge	Yes
Type of adjustable shelves	Glass	Type of internal light (fridge)	LED

Refrigerator Inner Door

Number of adjustable door shelves	2	No. of bottle shelves	1
-----------------------------------	---	-----------------------	---

Other technical features

Type of temperature control	Electro-mechanical
No. of compressors	1
Refrigerant gas type	R600a
Type of compressor	Standard

Refrigerant Quantity (gr)
Foam agent

28 g
Cyclopentane

Performance / Energy Label NEW 2019

			
Annual energy consumption	88 kWh/a	Sum of the volumes of the chill compartment(s) and the unfrozen compartment(s)	135 l
Energy efficiency class	E	Airborne acoustical noise emissions	35 dB(A) re 1pW
Airborne acoustical noise emission class	B	Climate class	SN, N, ST, T
Total net volume	135 l	EEL	96 %

Electrical Connection

Plug (F;E) Schuko
Current 0,35 A
Voltage (V) 220-240 V

Frequency (Hz) 50 Hz
Power supply cable length 150 cm

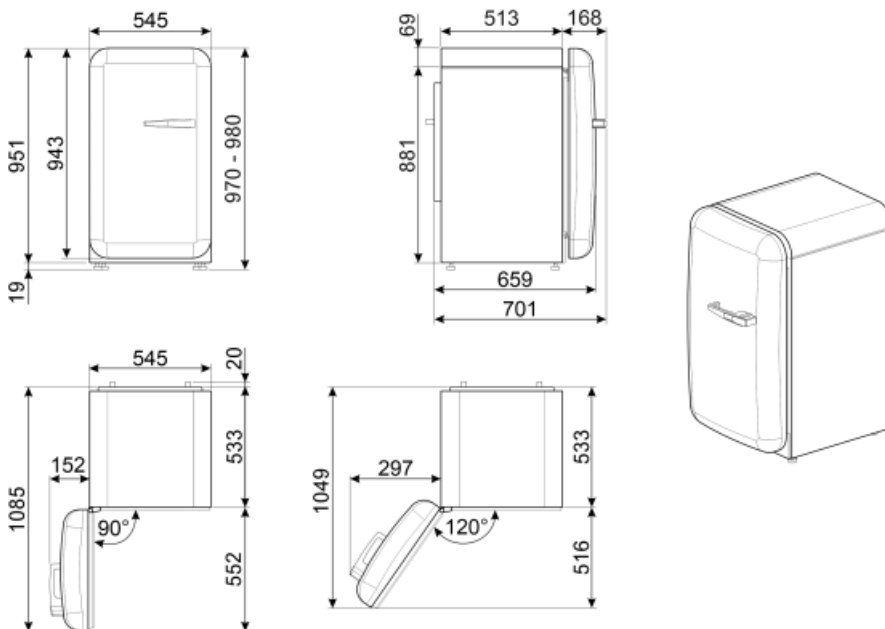

Symbols glossary (TT)



The automatic defrost system works by automatically defrosting at regular intervals eliminating the need to defrost altogether.



Energy efficiency class E



A++: Energy efficiency class A++ helps to save up to 20% energy compared to class A. Maximum performance with minimum consumption is guaranteed.



LED interior lighting: is a more energy efficient and long lasting way of illuminating the interior of the appliance.