

# FAB10HRBL5



|                  |               |
|------------------|---------------|
| Product Family   | Refrigerator  |
| Installation     | Free standing |
| Category         | One Door      |
| Reference width  | Until 60      |
| Reference height | Until 100     |
| Cooling type     | Static        |
| Defrost          | Automatic     |
| Hinge type       | Standard      |
| Hinge position   | Right         |
| EAN code         | 8017709298760 |



## Aesthetics

|           |              |               |         |
|-----------|--------------|---------------|---------|
| Aesthetic | 50's Style   | Handle type   | Fixed   |
| Colour    | Black        | Handle colour | Chrome  |
| Finishing | Glossy       | Logo colour   | Chrome  |
| Design    | Rounded      | Side material | Steel   |
| Material  | Heat-moulded | Side colour   | Black   |
| Handle    | External     | Logo          | Applied |

## Refrigerator compartment features



|                            |       |                                 |     |
|----------------------------|-------|---------------------------------|-----|
| No. of adjustable shelves  | 2     | Internal light in fridge        | Yes |
| Type of adjustable shelves | Glass | Type of internal light (fridge) | LED |

## Refrigerator Inner Door

|                                   |   |                       |   |
|-----------------------------------|---|-----------------------|---|
| Number of adjustable door shelves | 2 | No. of bottle shelves | 1 |
|-----------------------------------|---|-----------------------|---|

## Other Refrigerator features

|             |                                 |
|-------------|---------------------------------|
| Accessories | Bottle rack, Separatore lattine |
|-------------|---------------------------------|

## Other technical features

|                             |                    |
|-----------------------------|--------------------|
| Type of temperature control | Electro-mechanical |
| No. of compressors          | 1                  |
| Refrigerant gas type        | R600a              |
| Type of compressor          | Standard           |
| Refrigerant Quantity (gr)   | 28 g               |
| Foam agent                  | Cyclopentane       |

## Performance / Energy Label - Reg. 2019

|  |          |  |                  |
|--|----------|--|------------------|
|  Annual energy consumption | 88 kWh/a | Sum of the volumes of the chill compartment(s) and the unfrozen compartment(s) | 135 l            |
| Energy efficiency class  | E        | Airborne acoustical noise emissions  | 35 dB(A) re 1 pW |
| Airborne acoustical noise emission class   | B        | Climate class  | SN, N, ST, T     |
| Total net volume   | 135 l    | EI   | 96 %             |

## Electrical Connection

|                              |              |                           |           |
|------------------------------|--------------|---------------------------|-----------|
| Plug                         | (F;E) Schuko | Voltage (V)               | 220-240 V |
| Electrical connection rating | 50 W         | Frequency (Hz)            | 50 Hz     |
| Current                      | 0,35 A       | Power supply cable length | 180 cm    |

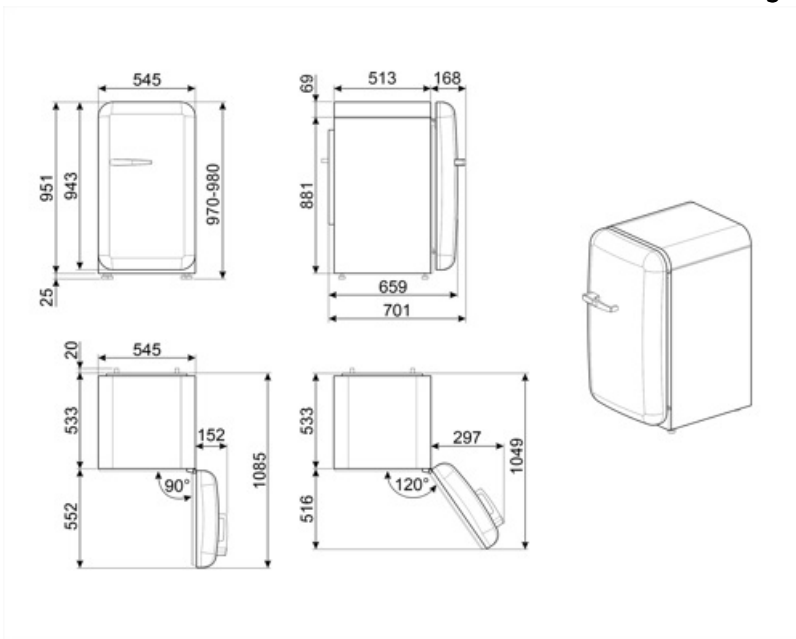

---

## Symbols glossary (TT)

---



LED interior lighting: is a more energy efficient and long lasting way of illuminating the interior of the appliance.



The automatic defrost system works by automatically defrosting at regular intervals eliminating the need to defrost altogether.



Energy efficiency class E