

FAB10HRBL5



Product Family	Refrigerator
Installation	Free Standing
Category	One Door
Reference width	Until 60
Reference height	Until 100
Cooling type	Static
Defrost	Automatic
Hinge type	Standard
Door opening flush with the wall	No
Slot-in	No
Hinge position	Right
Reversible door	No
EAN code	8017709298760



Aesthetics

Aesthetic	Estilo anos '50	Handle colour	Chrome
Colour	Black	Logo colour	Chrome
Acabamento	Brilhante	Side material	Steel
Design	Rounded	Side colour	Black
Material	Heat-moulded	Logotipo	Logotipo aplicado
Handle kit to be ordered separately	No	Display	No
Handle	External	Dispenser	No
Handle type	Fixed	HomeBar	No

Refrigerator compartment features



No. of adjustable shelves	2	Life Plus zone-0°C	No
Type of adjustable shelves	Glass	Compartimento baixa temperatura	No
Crisper Cover	No	Internal light in fridge	Yes
Bottle shelf	No	Type of internal light (fridge)	LED

Refrigerator Inner Door

Number of adjustable door shelves	2	No. of bottle shelves	1
Adjustable door shelves with wire support	No	Bottle shelves with wire support	No

Other Refrigerator features

Accessories	Bottle rack, Separador de latas	Ionizer	No
Natural Plus Blu Light	No	Tecnologia de titânio	No
MultiFlow	No	Filtro de odor antibacteriano	No
Fan	No	Zona de cuidados biológicos	No

Other technical features

Ligação à rede de água	No
Power on lamp	No
Temperature alarm lamp	No
Door open alarm	No
Temperature Alarm	No
Antibacterial Gasket	No
Type of temperature control	Electro-mechanical
No. of compressors	1
Refrigerant gas type	R600a
Type of compressor	Standard
Refrigerant Quantity (gr)	28 g
Espuma expansiva de isolamento	Ciclopentano

Etiqueta de Desempenho / Energia - Reg. 2019





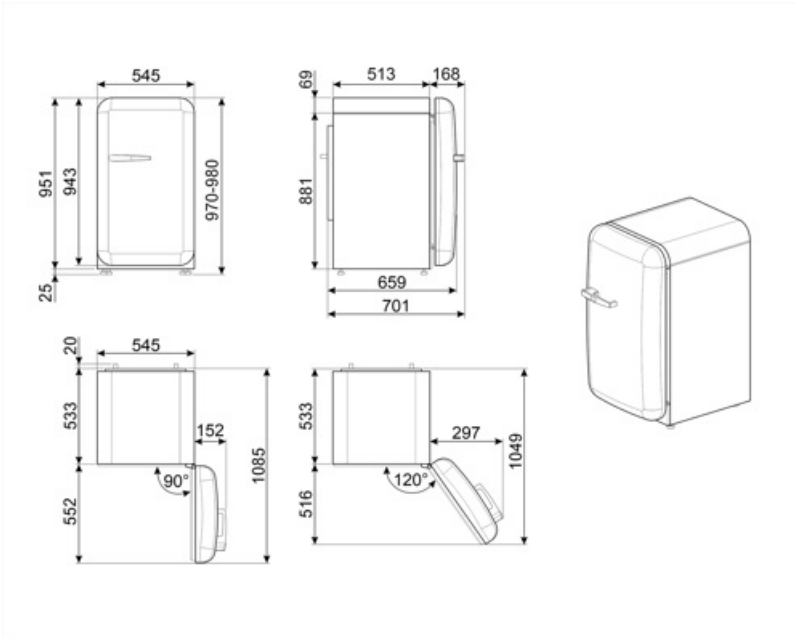

Consumo de energia anual	88 kWh/a	Soma dos volumes do(s) compartimento(s) refrigerado(s) e do(s) compartimento(s) não congelado(s)	135 l
Classe de eficiência energética	E	Airborne acoustical noise emissions	35 dB(A) re 1 pW
Classe de emissão de ruído acústico aerotransportado	B	Classe climática	SN, N, ST, T
Volume líquido total	135 l	EEI	96 %

Electrical Connection

Plug	(F;E) Schuko	Voltage (V)	220-240 V
Electrical connection rating	50 W	Frequency (Hz)	50 Hz
Current	0.35 A	Power supply cable length	180 cm



Symbols glossary

-  A++: A classe de eficiência energética A++ ajuda a economizar até 20% de energia em comparação com a classe A. O desempenho máximo com consumo mínimo é garantido.
-  Iluminação interior LED: é uma forma mais eficiente em termos energéticos e duradoura de iluminar o interior do aparelho.
-  O sistema de descongelamento automático funciona descongelando automaticamente em intervalos regulares, eliminando a necessidade de descongelar completamente.
-  Classe de eficiência energética E.

Benefit (TT)

Refrigerant gas R600a

Environmentally friendly R600a refrigerant gas contributes to rapid cooling with lower energy consumption

Climate class

Climatic class SN-T makes the appliance suitable for working at room temperature between 10 °C and 43 °C (50 °F ~ 109 °F)

External handle

The external handle ensures practicality and ease of use of the refrigerator

Refrigerator Internal lighting

Interior lighting for perfect visibility of shelves in the refrigerator compartment