

# FAB10HRPB5



Product Family	Refrigerator
Installation	Free standing
Category	One Door
Reference width	Until 60
Reference height	Until 100
Cooling type	Static
Defrost	Automatic
Hinge type	Standard
Hinge position	Right
EAN code	8017709297954



## Aesthetics

Aesthetic	50's Style	Handle type	Fixed
Colour	Pastel blue	Handle colour	Chrome
Finishing	Glossy	Logo colour	Chrome
Design	Rounded	Side material	Steel
Material	Heat-moulded	Side colour	Pastel blue
Handle	External	Logo	Applied

## Refrigerator compartment features



No. of adjustable shelves	2	Internal light in fridge	Yes
Type of adjustable shelves	Glass	Type of internal light (fridge)	LED

## Refrigerator Inner Door

Number of adjustable door shelves	2	No. of bottle shelves	1
-----------------------------------	---	-----------------------	---

## Other Refrigerator features

Accessories	Bottle rack, Separatore lattine
-------------	---------------------------------

## Other technical features

Type of temperature control	Electro-mechanical
No. of compressors	1
Refrigerant gas type	R600a
Type of compressor	Standard
Refrigerant Quantity (gr)	28 g
Foam agent	Cyclopentane

## Performance / Energy Label - Reg. 2019

 Annual energy consumption	88 kWh/a	Sum of the volumes of the chill compartment(s) and the unfrozen compartment(s)	135 l
Energy efficiency class	E	Airborne acoustical noise emissions	35 dB(A) re 1 pW
Airborne acoustical noise emission class	B	Climate class	SN, N, ST, T
Total net volume	135 l	EI	96 %

## Electrical Connection

Plug	(F;E) Schuko	Voltage (V)	220-240 V
Electrical connection rating	50 W	Frequency (Hz)	50 Hz
Current	0,35 A	Power supply cable length	180 cm

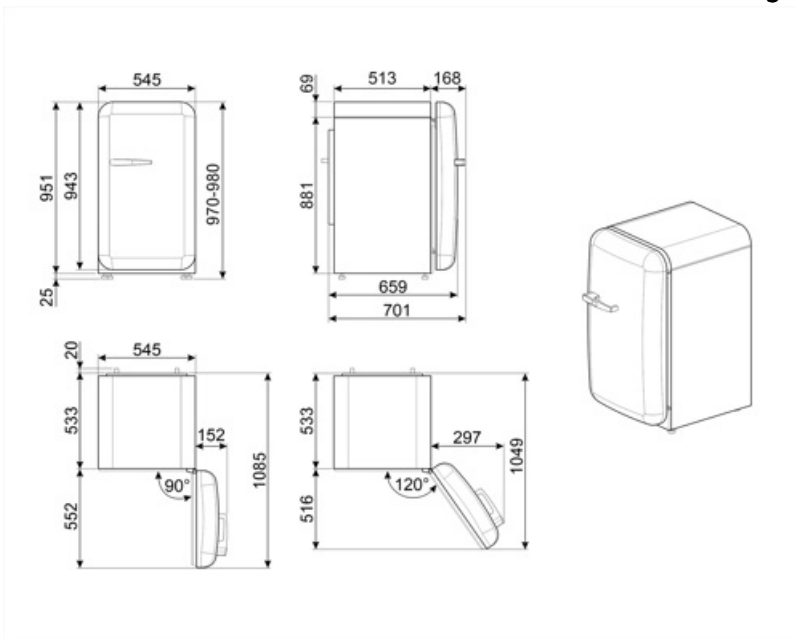

---

## Symbols glossary

---



LED interior lighting: is a more energy efficient and long lasting way of illuminating the interior of the appliance.



The automatic defrost system works by automatically defrosting at regular intervals eliminating the need to defrost altogether.



Energy efficiency class E