

FAB10URDSN3



Product Family	Refrigerator
Installation	Free standing
Category	One Door
Defrost	Automatic for refrigerator, manual for freezer
Hinge position	Left
EAN code	8017709326159



Aesthetics

Aesthetic	50's Style	Handle colour	Chrome
Colour	White	Logo colour	Chrome
Finishing	Glossy	Side material	Steel
Decoration / Special colour	Snoopy	Side colour	White
Collaborations	Smeg & Peanuts	Logo	Applied
Handle	External		

Refrigerator compartment features



No. of adjustable shelves	2	Crisper Cover	Yes
Number of fruit and vegetables drawers	1	Type of crisper/vegetable drawers cover	Glass
Type of adjustable shelves	Glass	Internal light in fridge	Yes
Type of crisper/vegetable drawers cover	Standard	Type of internal light (fridge)	LED

Refrigerator Inner Door

Number of adjustable door shelves	2	No. of bottle shelves	1
-----------------------------------	---	-----------------------	---

Freezer compartment features

Internal freezer compartment Yes

Other technical features

Type of temperature control	Electro-mechanical
No. of compressors	1
Refrigerant gas type	R600a
Type of compressor	Standard
Foam agent	Cyclopentane

Performance / Energy Label - Reg. 2019

Total gross volume	4.48 cu. ft.	Fresh Food compartment - Gross Volume	3.85 cu. ft.
Airborne acoustical noise emissions	37 dB(A) re 1 pW	Climate class	SN, N, ST, T
Gross volume frozen food compartment	0.64 cu. ft.		

Electrical Connection

Plug	(A) USA e Messico	Voltage (V)	120 V
Electrical connection rating	110 W	Frequency (Hz)	60 Hz
Current	1,25 A	Power supply cable length	70 7/8 "

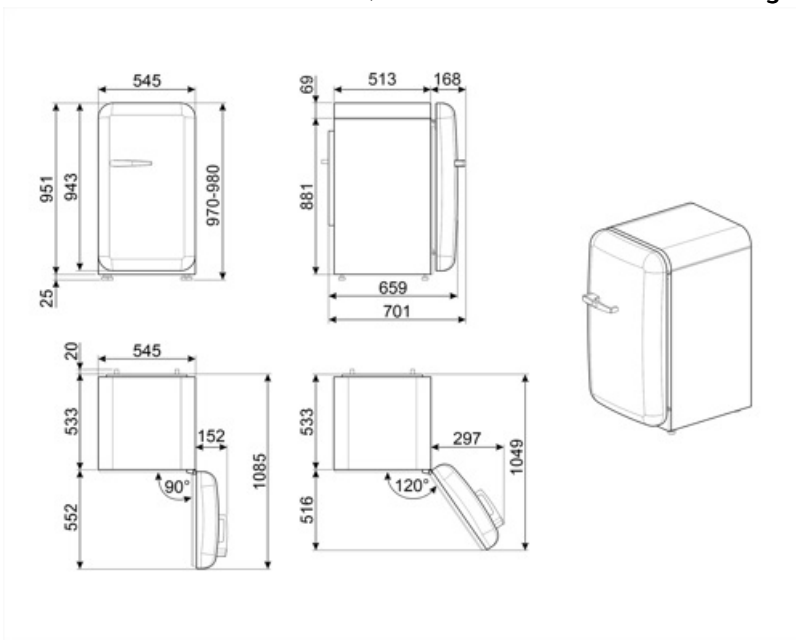

Symbols glossary



4 stars freezing compartment for better food preservation.



The automatic defrost system works by automatically defrosting at regular intervals eliminating the need to defrost altogether.



Energy efficiency class E



A++: Energy efficiency class A++ helps to save up to 20% energy compared to class A. Maximum performance with minimum consumption is guaranteed.



LED interior lighting: is a more energy efficient and long lasting way of illuminating the interior of the appliance.

Benefit (TT)

Refrigerant gas R600a

Environmentally friendly R600a refrigerant gas contributes to rapid cooling with lower energy consumption

Climate class

Climatic class SN-T makes the appliance suitable for working at room temperature between 10 °C and 43 °C (50 °F ~ 109 °F)

External handle

The external handle ensures practicality and ease of use of the refrigerator

Refrigerator Internal lighting

Interior lighting for perfect visibility of shelves in the refrigerator compartment

Fruit and vegetable drawer

The fruit and vegetable drawer ensures the best storage conditions for fresh food, avoiding any contamination