

# FAB28LCR5UK



Product Family	Refrigerator
Installation	Free Standing
Category	One Door
Reference width	Until 60
Reference height	100 - 160
Cooling type	Fan assisted refrigerator, static freezer
Defrost	Automatic for refrigerator, manual for freezer
Hinge type	Standard
Hinge position	Left
EAN code	8017709298937



## Aesthetics

Aesthetics	50's Style	Logo colour	Chrome
Colour	Cream	Side material	Steel
Finishing	Gloss	Side colour	Cream
Design	Rounded	Logo	Applied
Material	Heat-moulded	Door shelves profile colour	Chrome
Handle	External	Drawers profile colour	Chrome
Handle type	Fixed	Colour of glass shelf profile	Chrome
Handle colour	Chrome		

## Refrigerator compartment features



No. of adjustable shelves	2	Type of crisper/vegetable drawers cover	Glass
Number of fruit and vegetables drawers	1	Life Plus zone-0°C	Yes
Type of adjustable shelves	Glass	Internal light in fridge	Yes
Type of crisper/vegetable drawers cover	On sliding rails	Type of internal light (fridge)	LED
Crisper Cover	Yes		

## Refrigerator Inner Door

No. of bottle shelves	1
-----------------------	---

No. of door shelves with transparent cover 1

Bottle shelves with wire support Yes

Number of adjustable door shelves 1

Adjustable door shelves with wire support Yes

## Other Refrigerator features



MultiFlow

Yes

Fan

Yes

## Freezer compartment features

Internal freezer compartment Yes

## Other technical features



Door open alarm

Acoustic and visual

Type of temperature control

Electronic

No. of compressors

1

Refrigerant gas type

R600a

Type of compressor

Variable Speed Compressor

Refrigerant Quantity (gr)

32 g

Foam agent

Cyclopentane

## Performance / Energy Label NEW



Annual energy consumption 130 KWh/year

Noise level 35 dB(A) re 1 pW

Energy efficiency class D

Thaw time 9 h

Airborne acoustical noise emission class B

4 star - Freezing capacity 2.6 Kg/24h

Total volume 270 l

Climatic class SN, N, ST, T

Sum of the volumes of the frozen compartment(s) 26 l

EEl 79 %







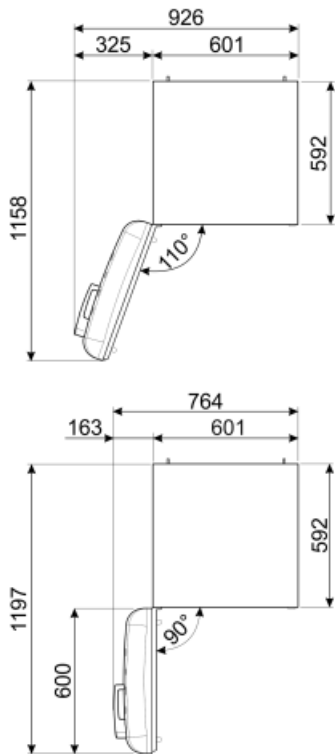
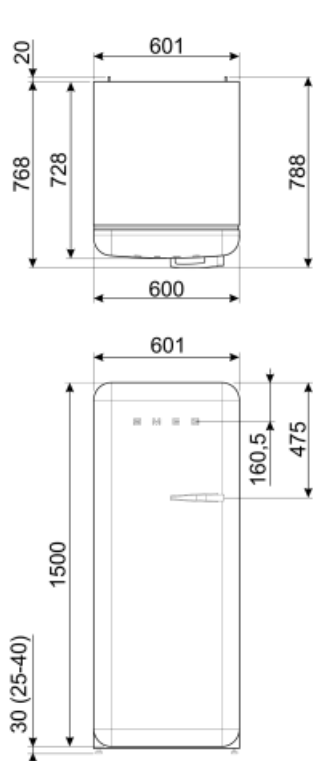

Sum of the volumes of the chill compartment(s) and the unfrozen compartment(s) 244 l

## Electrical Connection

Plug	(G) UK e Singapore	Voltage (V)	220-240 V
Nominal power	90 W	Frequency (Hz)	50/60 Hz
Current	1 A	Power supply cable length	180 cm



## Symbols glossary

-  4 stars freezing compartment for better food preservation.
-  The automatic defrost system works by automatically defrosting at regular intervals eliminating the need to defrost altogether.
-  LED interior lighting: is a more energy efficient and long lasting way of illuminating the interior of the appliance.
-  Inverter technology: The evolution of Smeg's driers towards more intelligent and environmentally sustainable models has led to the choice of using Inverter technology with heat pumps, which reduces significantly energy consumption.
-  Energy efficiency class D
-  A+++: Appliances with this symbol can reduce energy consumption by a further 30% from the standard A energy rating.
-  Ventilated: Forced distribution of cold air in the refrigerator compartment, which allows even temperature distribution within the fridge.
-  Life Plus 0°C: The temperature in the Lifeplus compartments is kept at 0°C, which preserves fresh meat and fish longer.
-  Air plus: keeps food fresher for longer.