

FAB28RBL5UK



Product Family	Refrigerator
Installation	Free standing
Category	One Door
Reference width	Until 60
Reference height	100 - 160
Cooling type	Fan assisted refrigerator, static freezer
Defrost	Automatic for refrigerator, manual for freezer
Hinge type	Standard
Hinge position	Right
EAN code	8017709299088



Aesthetics

Aesthetic	50's Style	Logo colour	Chrome
Colour	Black	Side material	Steel
Finishing	Glossy	Side colour	Black
Design	Rounded	Logo	Applied
Material	Heat-moulded	Door shelves profile color	Chrome
Handle	External	Drawers profile color	Chrome
Handle type	Fixed	Color of glass shelf profile	Chrome
Handle colour	Chrome	Alternative colours available	Pastel blue, White, Cream, Pink, Red, Silver, Pastel green, Decorated / Special

Refrigerator compartment features



No. of adjustable shelves	2	Type of crisper/vegetable drawers cover	Glass
Number of fruit and vegetables drawers	1	Life Plus zone-0°C	Yes
Type of adjustable shelves	Glass	Internal light in fridge	Yes
Type of crisper/vegetable drawers cover	On sliding rails	Type of internal light (fridge)	LED
Crisper Cover	Yes		

Refrigerator Inner Door

No. of door shelves with transparent cover	1	No. of bottle shelves	1
Number of adjustable door shelves	1	Bottle shelves with wire support	Yes
Adjustable door shelves with wire support	Yes		

Other Refrigerator features



MultiFlow

Yes

Fan

Yes

Freezer compartment features

Internal freezer compartment Yes

Other technical features



Door open alarm

Acoustic and visual

Type of temperature control

Electronic

No. of compressors

1

Refrigerant gas type

R600a

Type of compressor

Inverter

Refrigerant Quantity (gr)

32 g

Foam agent

Cyclopentane

Performance / Energy Label - Reg. 2019









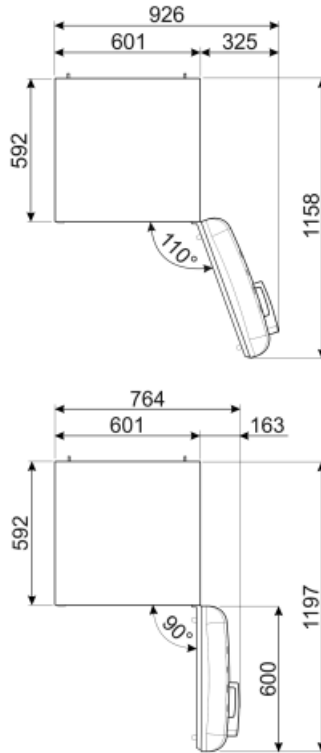
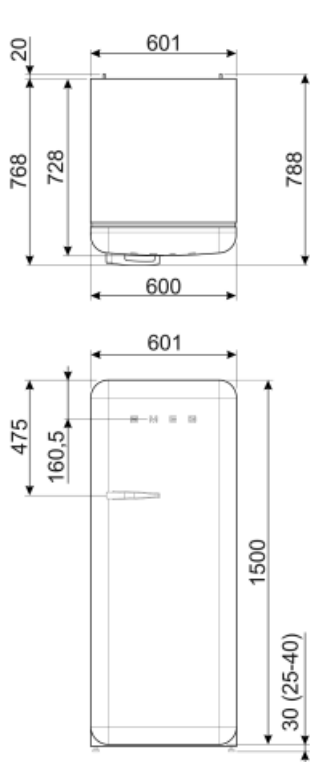

Annual energy consumption	130 kWh/a	Airborne acoustical noise emissions	35 dB(A) re 1 pW
Energy efficiency class	D	Temperature Rise Time	9 h
Airborne acoustical noise emission class	B	4 star - Freezing capacity	2.6 Kg/24h
Total net volume	270 l	Climate class	SN, N, ST, T
Sum of the volumes of the frozen compartment(s)	26 l	EEL	79 %
Sum of the volumes of the chill compartment(s) and the unfrozen compartment(s)	244 l		

Electrical Connection

Plug	(G) UK e Singapore	Voltage (V)	220-240 V
Electrical connection rating	90 W	Frequency (Hz)	50/60 Hz
Current	1 A	Power supply cable length	180 cm



Symbols glossary (TT)

	4 stars freezing compartment for better food preservation.		The automatic defrost system works by automatically defrosting at regular intervals eliminating the need to defrost altogether.
	A+++: Appliances with this symbol can reduce energy consumption by a further 30% from the standard A energy rating.		Energy efficiency class D
	Ventilated: Forced distribution of cold air in the refrigerator compartment, which allows even temperature distribution within the fridge.		LED interior lighting: is a more energy efficient and long lasting way of illuminating the interior of the appliance.
	Life Plus 0°C: The temperature in the Lifepius compartments is kept at 0°C, which preserves fresh meat and fish longer.		Smeg's evolution towards more intelligent and eco-friendly models has led to the choice of Inverter technology, which significantly reduces consumption.
	Multiflow Cooling System: the Multiflow ventilation system allows an even distribution of cool air around the fridge cabinet.		