

FAB28RDG



Product Family	Refrigerator
Installation	Free standing
Category	One Door
Cooling type	Fan assisted
Hinge type	Standard
Hinge position	Right
EAN code	8017709182700



Aesthetics

Aesthetic	50's Style	Handle colour	Gold
Colour	Gold	Logo colour	Gold-Swarovski
Design	Rounded	Side material	Steel
Finishing	Glossy	Side colour	Gold
Material	Heat-moulded	Logo	Applied
Handle	External	Display position	
Handle type	Fixed		

Refrigerator compartment features



No. of adjustable shelves	3	Type of crisper/vegetable drawers cover	Glass
Shelves material	Glass	Internal light in fridge	Yes
Crisper Cover	Yes	Type of internal light (fridge)	LED
Bottle shelf	Yes		

Refrigerator Inner Door

No. of door shelves with transparent cover	1	No. of bottle shelves	1
Number of adjustable door shelves	2	Bottle shelves with wire support	Yes
Adjustable door shelves with wire support	Yes		

Other Refrigerator features



Accessories	Bottle holder, 2 sliders	Ionizer
Fan	Yes	

Freezer compartment features

Internal freezer compartment	Yes
------------------------------	-----

Other technical features

Freezer compartment accessories	Ice cube tray
Water network connection	
Type of temperature control	Electro-mechanical
No. of compressors	1
Refrigerant gas type	R600a
Refrigerant Quantity (g)	44 g
Foam agent	Cyclopentane

Performance / Energy Label - Reg. 2019

Airborne acoustical noise emissions	39 dB(A) re 1 pW	Climate class	SN, N, ST, T
-------------------------------------	------------------	---------------	--------------

Electrical Connection

Electrical connection rating	90 W	Frequency (Hz)	50 Hz
Current	0,75 A	Power supply cable length	200 cm
Voltage (V)	220-240 V	Plug	(F;E) Schuko

Logistic Information

Width	600 mm	Product width with maximum doors opening	962 mm
Depth without handle	732 mm	Product depth with handle	732 mm
Height	1510 mm	Product depth with doors open at 90°	1148 mm

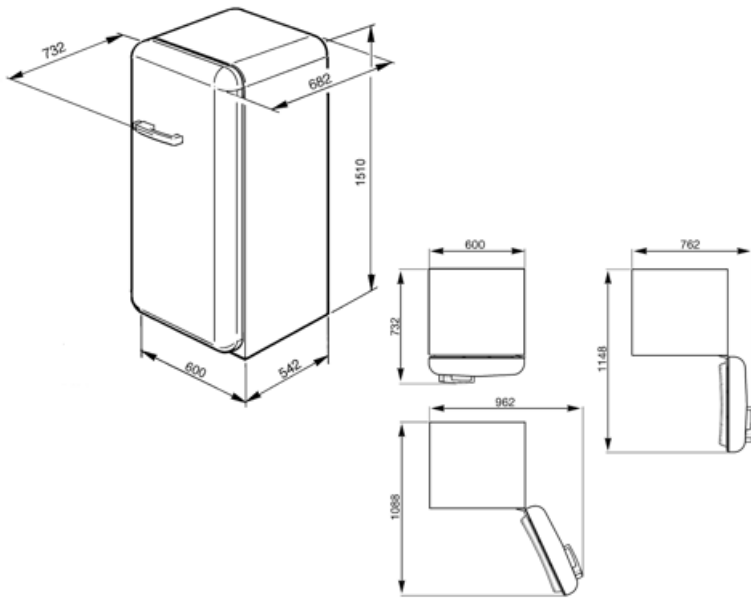

Symbols glossary



4 stars freezing compartment for better food preservation.



Ventilated: Forced distribution of cold air in the refrigerator compartment, which allows even temperature distribution within the fridge.



A++: Energy efficiency class A++ helps to save up to 20% energy compared to class A. Maximum performance with minimum consumption is guaranteed.



LED interior lighting: is a more energy efficient and long lasting way of illuminating the interior of the appliance.