

# FAB28RDGC5



<b>Product Family</b>	Refrigerator
<b>Installation</b>	Free standing
<b>Category</b>	One Door
<b>Reference width</b>	Until 60 cm
<b>Reference height</b>	100 - 160 cm
<b>Cooling type</b>	Fan assisted refrigerator, static freezer
<b>Defrost</b>	Automatic for refrigerator, manual for freezer
<b>Hinge type</b>	Standard
<b>Hinge position</b>	Right
<b>EAN code</b>	8017709299170



## Aesthetics

<b>Aesthetic</b>	50's Style	<b>Handle type</b>	Fixed
<b>Colour</b>	Decorated / Special	<b>Handle colour</b>	Chrome
<b>Decoration / Special colour</b>	Sicilian cart	<b>Logo colour</b>	Chrome
<b>Design</b>	Rounded	<b>Side material</b>	Steel
<b>Finishing</b>	Glossy	<b>Side colour</b>	Decorated / Special
<b>Series</b>	Divina Cucina	<b>Logo</b>	Applied
<b>Material</b>	Heat-moulded	<b>Door shelves profile color</b>	Chrome
<b>Collaborations</b>	Smeg & Dolce&Gabbana	<b>Drawers profile color</b>	Chrome
<b>Handle</b>	External	<b>Color of glass shelf profile</b>	Chrome

## Refrigerator compartment features



<b>Number of compartments</b>	2	<b>Crisper Cover</b>	Yes
<b>Compartment types</b>	Low temperature compartment, Fruit and vegetable compartment	<b>Type of crisper/vegetable drawers cover</b>	Glass
<b>No. of adjustable shelves</b>	2	<b>Low temperature compartment</b>	Yes
<b>Number of fruit and vegetables drawers</b>	1	<b>Internal light in fridge</b>	Yes
<b>Type of adjustable shelves</b>	Glass	<b>Type of internal light (fridge)</b>	LED

Type of crisper/vegetable drawers cover On sliding rails

## Refrigerator Inner Door

No. of door shelves with transparent cover	1	No. of bottle shelves	1
Number of adjustable door shelves	1	Bottle shelves with wire support	Yes
Adjustable door shelves with wire support	Yes		

## Other Refrigerator features



MultiFlow	Yes	Fan	Yes
-----------	-----	-----	-----

## Freezer compartment features

Internal freezer compartment Yes

## Other technical features



Door open alarm	Acoustic and visual
Type of temperature control	Electronic
No. of compressors	1
Refrigerant gas type	R600a
Type of compressor	Inverter
Refrigerant Quantity (g)	32 g
Foam agent	Cyclopentane

## Performance / Energy Label - Reg. 2019



Annual energy consumption	130 kWh/a	Airborne acoustical noise emissions	35 dB(A) re 1 pW
Energy efficiency class	D	Temperature Rise Time	9 h
Airborne acoustical noise emission class	B	4 star - Freezing capacity	2,6 kg/24h
Total net volume	270 l	Climate class	SN, N, ST, T
Sum of the volumes of the frozen compartment(s)	26 l	EEL	79 %

Sum of the volumes of the chill compartment(s) and the unfrozen compartment(s) 244 l

## Electrical Connection







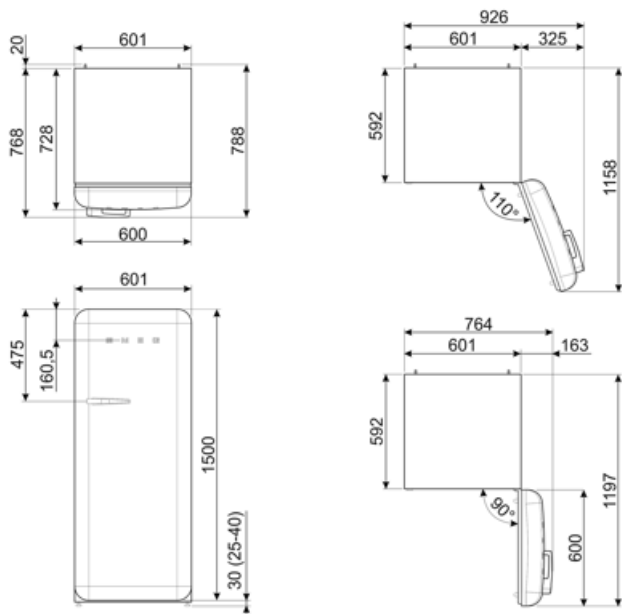

Electrical connection rating	90 W	Frequency (Hz)	50/60 Hz
Current	1 A	Power supply cable length	180 cm
Voltage (V)	220-240 V	Plug	(F;E) Schuko

## Logistic Information

Width	601 mm	Product width with maximum doors opening	926 mm
Depth without handle	728 mm	Product depth with handle	768 mm
Height	1530 mm	Product depth with doors open at 90°	1197 mm



## Symbols glossary

- |  |   |   |  |
|--|---|---|--|
|  | 4 stars freezing compartment for better food preservation.  |  | A+++: Appliances with this symbol can reduce energy consumption by a further 30% from the standard A energy rating.                                      |
|  | The automatic defrost system works by automatically defrosting at regular intervals eliminating the need to defrost altogether. |  | Ventilated: Forced distribution of cold air in the refrigerator compartment, which allows even temperature distribution within the fridge.               |
|  | LED interior lighting: is a more energy efficient and long lasting way of illuminating the interior of the appliance.           |  | Smeg's evolution towards more intelligent and eco-friendly models has led to the choice of Inverter technology, which significantly reduces consumption. |
|  | Multiflow Cooling System: the Multiflow ventilation system allows an even distribution of cool air around the fridge cabinet.   |  | Energy efficiency class D  |