

# FAB28RPB3UK



Product Family	Refrigerator
Installation	Free standing
Category	One Door
Cooling type	Fan assisted
Defrost	Automatic for refrigerator, manual for freezer
Hinge type	Standard
Hinge position	Right
EAN code	8017709260873



## Aesthetics

Aesthetic	50's Style	Logo colour	Chrome
Colour	Pastel blue	Side material	Steel
Finishing	Glossy	Side colour	Pastel blue
Design	Rounded	Logo	Applied
Material	Heat-moulded	Door shelves profile color	Chrome
Handle	External	Drawers profile color	Chrome
Handle type	Fixed	Color of glass shelf profile	Chrome
Handle colour	Chrome	Alternative colours available	White, Black, Cream, Pink, Red, Silver, Pastel green, Decorated / Special

## Refrigerator compartment features



No. of adjustable shelves	1	Type of crisper/vegetable drawers cover	Glass
Number of fruit and vegetables drawers	1	Life Plus zone-0°C	-2°C +3 °C
Type of adjustable shelves	Glass	Internal light in fridge	Yes
Type of crisper/vegetable drawers cover	On sliding rails	Type of internal light (fridge)	LED
Crisper Cover	Yes		

## Refrigerator Inner Door

No. of door shelves with transparent cover 1  
 Number of adjustable door shelves 1  
 Adjustable door shelves with wire support Yes

No. of bottle shelves 1  
 Bottle shelves with wire support Yes

## Other Refrigerator features



MultiFlow Yes

Fan Yes

## Freezer compartment features

Internal freezer compartment Yes

## Other technical features



Door open alarm	Acoustic and visual
Antibacterial Gasket	Yes
Type of temperature control	Electronic
No. of compressors	1
Refrigerant gas type	R600a
Type of compressor	Inverter
Refrigerant Quantity (gr)	34 g
Foam agent	Cyclopentane

## Performance / Energy Label - Reg. 2019



Annual energy consumption	245 kWh/a	Airborne acoustical noise emissions	38 dB(A) re 1pW
Energy efficiency class	G	Temperature Rise Time	9.9 h
Airborne acoustical noise emission class	C	4 star - Freezing capacity	2.6 Kg/24h
Total net volume	270 l	Climate class	SN, N, ST, T
Sum of the volumes of the frozen compartment(s)	26 l	EEI	150 %
Sum of the volumes of the chill compartment(s) and the unfrozen compartment(s)	244 l		

## Electrical Connection



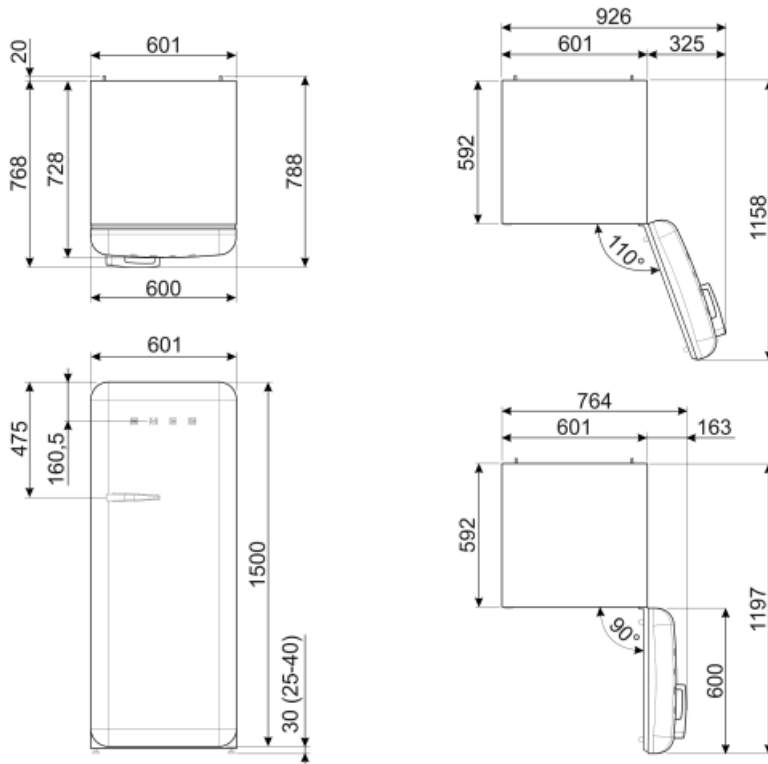







<b>Plug</b>	(G) UK e Singapore	<b>Voltage (V)</b>	220-240 V
<b>Electrical connection rating</b>	90 W	<b>Frequency (Hz)</b>	50/60 Hz
<b>Current</b>	1 A	<b>Power supply cable length</b>	180 cm



---

## Symbols glossary (TT)

---

	4 stars freezing compartment for better food preservation.		The automatic defrost system works by automatically defrosting at regular intervals eliminating the need to defrost altogether.
	A+++: Appliances with this symbol can reduce energy consumption by a further 30% from the standard A energy rating.		Antibacterial treatment: antibacterial treatment to ensure better hygiene
	Ventilated: Forced distribution of cold air in the refrigerator compartment, which allows even temperature distribution within the fridge.		Energy efficiency class G
	LED interior lighting: is a more energy efficient and long lasting way of illuminating the interior of the appliance.		Life Plus 0°C: The temperature in the Lifeplus compartments is kept at 0°C, which preserves fresh meat and fish longer.
	Smeg's evolution towards more intelligent and eco-friendly models has led to the choice of Inverter technology, which significantly reduces consumption.		Air plus: keeps food fresher for longer.