

FAB28RPB5UK



Product Family	Refrigerator
Installation	Free Standing
Category	One Door
Reference width	Until 60
Reference height	100 - 160
Cooling type	Fan assisted refrigerator, static freezer
Defrost	Automatic for refrigerator, manual for freezer
Hinge type	Standard
Hinge position	Right
EAN code	8017709299286



Aesthetics

Aesthetics	50's Style	Logo colour	Chrome
Colour	Pastel Blue	Side material	Steel
Finishing	Gloss	Side colour	Pastel blue
Design	Rounded	Logo	Applied
Material	Heat-moulded	Door shelves profile colour	Chrome
Handle	External	Drawers profile colour	Chrome
Handle type	Fixed	Colour of glass shelf profile	Chrome
Handle colour	Chrome	Colori disponibili	White, Black, Cream, Pink, Red, Silver, Pastel green, Decorated / Special

Refrigerator compartment features



No. of adjustable shelves	1	Type of crisper/vegetable drawers cover	Glass
Number of fruit and vegetables drawers	1	Life Plus zone-0°C	Yes
Type of adjustable shelves	Glass	Internal light in fridge	Yes
Type of crisper/vegetable drawers cover	On sliding rails	Type of internal light (fridge)	LED
Crisper Cover	Yes		

Refrigerator Inner Door

No. of door shelves with transparent cover 1
 Number of adjustable door shelves 1
 Adjustable door shelves with wire support Yes

No. of bottle shelves 1
 Bottle shelves with wire support Yes

Other Refrigerator features



MultiFlow

Yes

Fan

Yes

Freezer compartment features

Internal freezer compartment Yes

Other technical features



Door open alarm

Acoustic and visual

Type of temperature control

Electronic

No. of compressors

1

Refrigerant gas type

R600a

Type of compressor

Variable Speed Compressor

Refrigerant Quantity (gr)

32 g

Foam agent

Cyclopentane

Performance / Energy Label



Annual energy consumption 130 kWh/year

Noise level 35 dB(A) re 1 pW

Energy efficiency class D

Thaw time 9 h

Airborne acoustical noise emission class B

4 star - Freezing capacity 2.6 Kg/24h

Total volume 270 l

Climatic class SN, N, ST, T

Sum of the volumes of the frozen compartment(s) 26 l

EEl 79 %







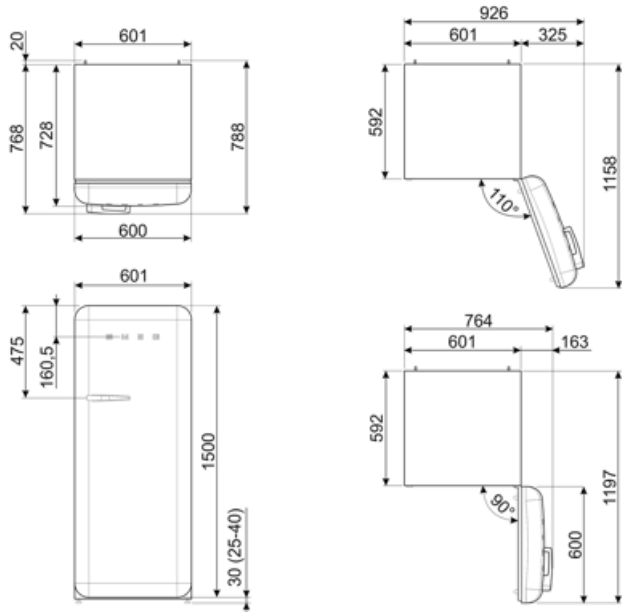

Sum of the volumes of the chill compartment(s) and the unfrozen compartment(s) 244 l

Electrical Connection

Plug	(G) UK e Singapore	Voltage (V)	220-240 V
Nominal power	90 W	Frequency (Hz)	50/60 Hz
Current	1 A	Power supply cable length	180 cm



Symbols glossary

-  4 stars freezing compartment for better food preservation.
-  The automatic defrost system works by automatically defrosting at regular intervals eliminating the need to defrost altogether.
-  LED interior lighting: is a more energy efficient and long lasting way of illuminating the interior of the appliance.
-  Inverter technology: The evolution of Smeg's driers towards more intelligent and environmentally sustainable models has led to the choice of using Inverter technology with heat pumps, which reduces significantly energy consumption.
-  Energy efficiency class D
-  A+++: Appliances with this symbol can reduce energy consumption by a further 30% from the standard A energy rating.
-  Ventilated: Forced distribution of cold air in the refrigerator compartment, which allows even temperature distribution within the fridge.
-  Life Plus 0°C: The temperature in the Lifeplus compartments is kept at 0°C, which preserves fresh meat and fish longer.
-  Air plus: keeps food fresher for longer.