

FAB30LBL5



| | |
|-----------------|---|
| Product Family | Refrigerator |
| Installation | Free standing |
| Category | Top Mount |
| Reference width | Until 60 |
| Cooling type | Fan assisted refrigerator, static freezer |
| Defrost | Manual |
| Hinge type | Standard |
| Hinge position | Left |
| EAN code | 8017709297640 |



Aesthetics

| | | | |
|---------------|--------------|-------------------------------|---|
| Aesthetic | 50's Style | Logo colour | Chrome |
| Colour | Black | Side material | Steel |
| Finishing | Glossy | Side colour | Black |
| Design | Rounded | Logo | Applied |
| Material | Heat-moulded | Door shelves profile color | Chrome |
| Handle | External | Drawers profile color | Chrome |
| Handle type | Fixed | Color of glass shelf profile | Chrome |
| Handle colour | Chrome | Alternative colours available | Orange, Pastel blue, White, Blue, Black, Cream, Pink, Red, Silver, Pastel green, Lime green |

Refrigerator compartment features



| | | | |
|---|------------------|---|-------|
| No. of adjustable shelves | 2 | Type of crisper/vegetable drawers cover | Glass |
| Number of fruit and vegetables drawers | 1 | Life Plus zone-0°C | Yes |
| Type of adjustable shelves | Glass | Internal light in fridge | Yes |
| Type of crisper/vegetable drawers cover | On sliding rails | Type of internal light (fridge) | LED |
| Crisper Cover | Yes | | |

Refrigerator Inner Door

| | | | |
|--|-----|----------------------------------|-----|
| No. of door shelves with transparent cover | 1 | No. of bottle shelves | 1 |
| Number of adjustable door shelves | 2 | Bottle shelves with wire support | Yes |
| Adjustable door shelves with wire support | Yes | | |

Other Refrigerator features



| | | | |
|-----------|-----|-----|-----|
| MultiFlow | Yes | Fan | Yes |
|-----------|-----|-----|-----|

Freezer compartment features

| | | | |
|----------------|---|-----------------|------|
| No. of shelves | 1 | Type of shelves | Wire |
|----------------|---|-----------------|------|

Other technical features



| | |
|-----------------------------|---------------------|
| Door open alarm | Acoustic and visual |
| Type of temperature control | Electronic |
| No. of compressors | 1 |
| Refrigerant gas type | R600a |
| Type of compressor | Inverter |
| Refrigerant Quantity (gr) | 70 g |
| Foam agent | Cyclopentane |

Performance / Energy Label - Reg. 2019



| | | | |
|--|-----------|-------------------------------------|------------------|
| Annual energy consumption | 168 kWh/a | Airborne acoustical noise emissions | 37 dB(A) re 1 pW |
| Energy efficiency class | D | Temperature Rise Time | 30 h |
| Airborne acoustical noise emission class | C | 4 star - Freezing capacity | 4 Kg/24h |
| Total net volume | 294 l | Climate class | SN, N, ST, T |
| Sum of the volumes of the frozen compartment(s) | 72 l | EI | 80 % |
| Sum of the volumes of the chill compartment(s) and the unfrozen compartment(s) | 222 l | | |

Electrical Connection

| | | | |
|-------------------------------------|--------------|----------------------------------|-----------|
| Plug | (F;E) Schuko | Voltage (V) | 220-240 V |
| Electrical connection rating | 100 W | Frequency (Hz) | 50/60 Hz |
| Current | 0,8 A | Power supply cable length | 180 cm |

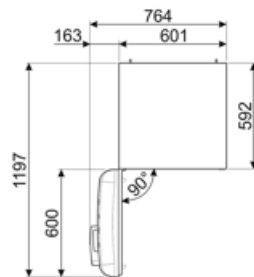
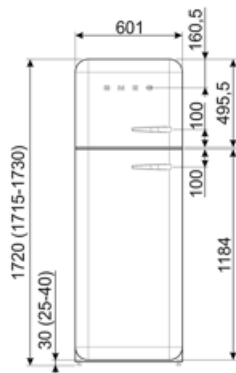
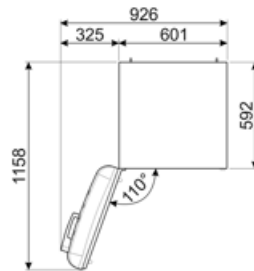
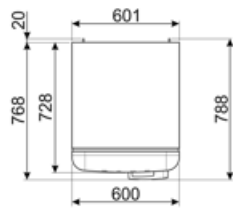

Alternative products



FAB30LPK5

Hinge position: Left
Pink



FAB30LSV5

Hinge position: Left
Silver



FAB30RPK5

Hinge position: Right
Pink



FAB30RCR5

Hinge position: Right
Cream



FAB30RBL5

Hinge position: Right
Black



FAB30RPB5

Hinge position: Right
Pastel blue



FAB30LOR5

Hinge position: Left
Orange



FAB30RRD5

Hinge position: Right
Red



FAB30RPG5

Hinge position: Right
Pastel green



FAB30RWH5

Hinge position: Right
White



FAB30ROR5

Hinge position: Right
Orange



FAB30LPG5

Hinge position: Left
Pastel green



FAB30RLI5

Hinge position: Right
Lime green



FAB30LPB5

Hinge position: Left
Pastel blue



FAB30LRD5

Hinge position: Left
Red



FAB30LCR5

Hinge position: Left
Cream



FAB30RSV5

Hinge position: Right
Silver



FAB30LWH5









Hinge position: Left
White



FAB30RBE5

Hinge position: Right
Blue

Symbols glossary

-  4 stars freezing compartment for better food preservation.
-  Ventilated: Forced distribution of cold air in the refrigerator compartment, which allows even temperature distribution within the fridge.
-  Life Plus 0°C: The temperature in the Lifeplus compartments is kept at 0°C, which preserves fresh meat and fish longer.
-  Multiflow Cooling System: the Multiflow ventilation system allows an even distribution of cool air around the fridge cabinet.
-  A+++: Appliances with this symbol can reduce energy consumption by a further 30% from the standard A energy rating.
-  LED interior lighting: is a more energy efficient and long lasting way of illuminating the interior of the appliance.
-  Smeg's evolution towards more intelligent and eco-friendly models has led to the choice of Inverter technology, which significantly reduces consumption.
-  Energy efficiency class D