

FAB30LPB5UK



| | |
|-----------------|---|
| Product Family | Refrigerator |
| Installation | Free Standing |
| Category | Top Mount |
| Reference width | Until 60 |
| Cooling type | Fan assisted refrigerator, static freezer |
| Defrost | Manual |
| Hinge type | Standard |
| Hinge position | Left |
| EAN code | 8017709298418 |



Aesthetics

| | | | |
|---------------|--------------|-------------------------------|---|
| Aesthetics | 50's Style | Logo colour | Chrome |
| Colour | Pastel Blue | Side material | Steel |
| Finishing | Gloss | Side colour | Pastel blue |
| Design | Rounded | Logo | Applied |
| Material | Heat-moulded | Door shelves profile colour | Chrome |
| Handle | External | Drawers profile colour | Chrome |
| Handle type | Fixed | Colour of glass shelf profile | Chrome |
| Handle colour | Chrome | Colori disponibili | Orange, Pastel blue, White, Blue, Black, Cream, Pink, Red, Silver, Pastel green, Lime green |

Refrigerator compartment features



| | | | |
|---|------------------|---|-------|
| No. of adjustable shelves | 2 | Type of crisper/vegetable drawers cover | Glass |
| Number of fruit and vegetables drawers | 1 | Life Plus zone-0°C | Yes |
| Type of adjustable shelves | Glass | Internal light in fridge | Yes |
| Type of crisper/vegetable drawers cover | On sliding rails | Type of internal light (fridge) | LED |
| Crisper Cover | Yes | | |

Refrigerator Inner Door

| | | | |
|--|-----|----------------------------------|-----|
| No. of door shelves with transparent cover | 1 | No. of bottle shelves | 1 |
| Number of adjustable door shelves | 2 | Bottle shelves with wire support | Yes |
| Adjustable door shelves with wire support | Yes | | |

Other Refrigerator features



| | | | |
|-----------|-----|-----|-----|
| MultiFlow | Yes | Fan | Yes |
|-----------|-----|-----|-----|

Freezer compartment features

| | | | |
|----------------|---|-----------------|------|
| No. of shelves | 1 | Type of shelves | Wire |
|----------------|---|-----------------|------|

Other Freezer features

| | |
|----------------|-----|
| Ice tray shelf | Yes |
|----------------|-----|

Other technical features



| | |
|-----------------------------|---------------------------|
| Door open alarm | Acoustic and visual |
| Type of temperature control | Electronic |
| No. of compressors | 1 |
| Refrigerant gas type | R600a |
| Type of compressor | Variable Speed Compressor |
| Refrigerant Quantity (gr) | 70 g |
| Foam agent | Cyclopentane |

Performance / Energy Label



| | | | |
|--|--------------|----------------------------|------------------|
| Annual energy consumption | 168 KWh/year | Noise level | 37 dB(A) re 1 pW |
| Energy efficiency class | D | Thaw time | 30 h |
| Airborne acoustical noise emission class | C | 4 star - Freezing capacity | 4 Kg/24h |
| Total volume | 294 l | Climatic class | SN, N, ST, T |
| | | EEl | 80 % |

Sum of the volumes of the frozen compartment(s) 72 l

Sum of the volumes of the chill compartment(s) and the unfrozen compartment(s) 222 l

Electrical Connection

| | | | |
|---------------|--------------------|---------------------------|-----------|
| Plug | (G) UK e Singapore | Voltage (V) | 220-240 V |
| Nominal power | 100 W | Frequency (Hz) | 50/60 Hz |
| Current | 0,8 A | Power supply cable length | 180 cm |

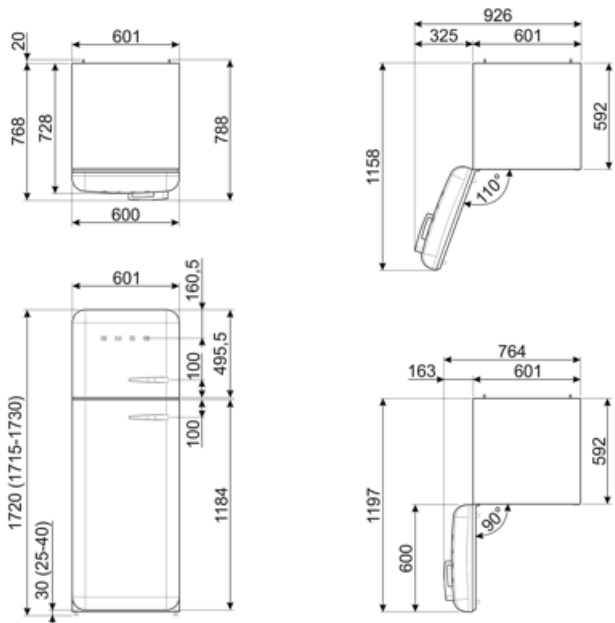

Alternative products



FAB30RCR5UK

Hinge position: Right
Cream



FAB30LCR5UK

Hinge position: Left
Cream



FAB30RWH5UK

Hinge position: Right
White



FAB30LBL5UK

Hinge position: Left
Black



FAB30LWH5UK

Hinge position: Left
White



FAB30RPB5UK

Hinge position: Right
Pastel Blue



FAB30RPG5UK

Hinge position: Right
Pastel Green



FAB30RRD5UK

Hinge position: Right
Red



FAB30LPG5UK

Hinge position: Left
Pastel Green



FAB30RBL5UK









Hinge position: Right
Black



FAB30LRD5UK

Hinge position: Left
Red

Symbols glossary

-  4 stars freezing compartment for better food preservation.
-  Ventilated: Forced distribution of cold air in the refrigerator compartment, which allows even temperature distribution within the fridge.
-  Life Plus 0°C: The temperature in the Lifeplus compartments is kept at 0°C, which preserves fresh meat and fish longer.
-  Air plus: keeps food fresher for longer.
-  A+++: Appliances with this symbol can reduce energy consumption by a further 30% from the standard A energy rating.
-  LED interior lighting: is a more energy efficient and long lasting way of illuminating the interior of the appliance.
-  Inverter technology: The evolution of Smeg's driers towards more intelligent and environmentally sustainable models has led to the choice of using Inverter technology with heat pumps, which reduces significantly energy consumption.
-  Energy efficiency class D