

FAB30LWH6UK



| | |
|-------------------------|---|
| Product Family | Refrigerator |
| Installation | Free Standing |
| Category | Top Mount |
| Reference width | Until 60 cm |
| Reference height | 160 - 200 cm |
| Cooling type | Fan assisted refrigerator, static freezer |
| Defrost | Manual |
| Hinge type | Standard |
| Hinge position | Left |
| EAN code | 8017709358372 |



Aesthetics

| | | | |
|----------------------|--------------|--------------------------------------|---|
| Aesthetics | 50's Style | Logo colour | Chrome |
| Colour | White | Side material | Steel |
| Design | Rounded | Side colour | White |
| Finishing | Gloss | Logo | Applied |
| Material | Heat-moulded | Door shelves profile colour | Chrome |
| Handle | External | Drawers profile colour | Chrome |
| Handle type | Fixed | Colour of glass shelf profile | Chrome |
| Handle colour | Chrome | Colori disponibili | Orange, Pastel blue, White, Blue, Black, Cream, Pink, Red, Silver, Pastel green, Lime green |

Refrigerator compartment features



| | | | |
|---|--|--|-------|
| Number of compartments | 2 | Crisper Cover | Yes |
| Compartment types | Low temperature compartment, Fruit and vegetable compartment | Type of crisper/vegetable drawers cover | Glass |
| No. of adjustable shelves | 2 | No. of lights | 2 |
| Number of fruit and vegetables drawers | 1 | Low temperature compartment | Yes |
| Shelves material | Glass | Internal light in fridge | Yes |
| | | Type of internal light (fridge) | LED |

Type of crisper/vegetable drawers cover Standard

Refrigerator Inner Door

| | | | |
|--|-----|----------------------------------|-----|
| No. of door shelves with transparent cover | 1 | No. of bottle shelves | 1 |
| Number of adjustable door shelves | 2 | Bottle shelves with wire support | Yes |
| Adjustable door shelves with wire support | Yes | | |

Other Refrigerator features



MultiFlow

Yes

Fan

Yes

Freezer compartment features

| | | | |
|----------------|---|-----------------|------|
| No. of shelves | 1 | Type of shelves | Wire |
|----------------|---|-----------------|------|

Other technical features



| | |
|-----------------------------|---------------------|
| Door open alarm | Acoustic and visual |
| Type of temperature control | Electronic |
| No. of compressors | 1 |
| Refrigerant gas type | R600a |
| Type of compressor | Inverter |
| Refrigerant Quantity (g) | 68 g |
| Foam agent | Cyclopentane |

Performance / Energy Label



| | | | |
|---|--------------|----------------------------|------------------|
| Annual energy consumption | 135 kWh/year | Noise level | 34 dB(A) re 1 pW |
| Energy efficiency class | C | Thaw time | 20 h |
| Airborne acoustical noise emission class | B | 4 star - Freezing capacity | 4 kg/24h |
| Total volume | 294 l | Climatic class | SN, N, ST, T |
| Sum of the volumes of the frozen compartment(s) | 72 l | EEl | 64 % |

Sum of the volumes of the chill compartment(s) and the unfrozen compartment(s) 222 l

Electrical Connection

| | | | |
|---------------|-----------|---------------------------|--------------------|
| Nominal power | 100 W | Frequency (Hz) | 50/60 Hz |
| Current | 0,8 A | Power supply cable length | 180 cm |
| Voltage (V) | 220-240 V | Plug | (G) UK e Singapore |

Logistic Information

| | | | |
|--|---------|--------------------------------------|---------|
| Width (mm) | 600 mm | Product depth with handle | 768 mm |
| Depth without handle | 728 mm | Product depth with doors open at 90° | 1197 mm |
| Product Height with feet | 1720 mm | Spacer depth | 20 mm |
| Product width with maximum doors opening | 926 mm | | |

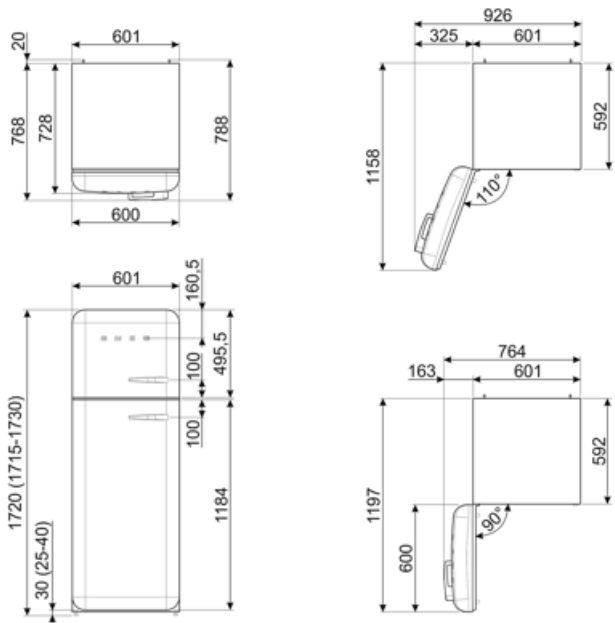

Alternative products



FAB30LCR6UK

Hinge position: Left
Cream



FAB30LPB6UK

Hinge position: Left
Pastel Blue



FAB30LRD6UK

Hinge position: Left
Red



FAB30LBL6UK







Hinge position: Left
Black



FAB30LPG6UK

Hinge position: Left
Pastel Green

Symbols glossary

-  4 stars freezing compartment for better food preservation.
-  Ventilated: Forced distribution of cold air in the refrigerator compartment, which allows even temperature distribution within the fridge.
-  Inverter technology: The evolution of Smeg's driers towards more intelligent and environmentally sustainable models has led to the choice of using Inverter technology with heat pumps, which reduces significantly energy consumption.
-  Energy efficiency class C
-  A+++: Appliances with this symbol can reduce energy consumption by a further 30% from the standard A energy rating.
-  LED interior lighting: is a more energy efficient and long lasting way of illuminating the interior of the appliance.
-  Air plus: keeps food fresher for longer.