

FAB30RCR5



Product Family	Refrigerator
Installation	Free standing
Category	Top Mount
Reference width	Until 60
Cooling type	Fan assisted refrigerator, static freezer
Defrost	Manual
Hinge type	Standard
Hinge position	Right
EAN code	8017709297763



Aesthetics

Aesthetic	50's Style	Logo colour	Chrome
Colour	Cream	Side material	Steel
Finishing	Glossy	Side colour	Cream
Design	Rounded	Logo	Applied
Material	Heat-moulded	Door shelves profile color	Chrome
Handle	External	Drawers profile color	Chrome
Handle type	Fixed	Color of glass shelf profile	Chrome
Handle colour	Chrome		

Refrigerator compartment features



No. of adjustable shelves	2	Type of crisper/vegetable drawers cover	Glass
Number of fruit and vegetables drawers	1	Life Plus zone-0°C	Yes
Type of adjustable shelves	Glass	Internal light in fridge	Yes
Type of crisper/vegetable drawers cover	On sliding rails	Type of internal light (fridge)	LED
Crisper Cover	Yes		

Refrigerator Inner Door

No. of bottle shelves	1
-----------------------	---

No. of door shelves with transparent cover	1	Bottle shelves with wire support	Yes
Number of adjustable door shelves	2		
Adjustable door shelves with wire support	Yes		

Other Refrigerator features



MultiFlow	Yes	Fan	Yes
-----------	-----	-----	-----

Freezer compartment features

No. of shelves	1	Type of shelves	Wire
----------------	---	-----------------	------

Other technical features



Door open alarm	Acoustic and visual
Type of temperature control	Electronic
No. of compressors	1
Refrigerant gas type	R600a
Type of compressor	Inverter
Refrigerant Quantity (gr)	70 g
Foam agent	Cyclopentane

Performance / Energy Label NEW 2019



Annual energy consumption	168 kWh/a	Airborne acoustical noise emissions	37 dB(A) re 1pW
Energy efficiency class	D	Temperature Rise Time	30 h
Airborne acoustical noise emission class	C	4 star - Freezing capacity	4 Kg/24h
Total net volume	294 l	Climate class	SN, N, ST, T
Sum of the volumes of the frozen compartment(s)	72 l	EEl	80 %
Sum of the volumes of the chill compartment(s) and the unfrozen compartment(s)	222 l		

Electrical Connection

Plug	(F;E) Schuko	Voltage (V)	220-240 V
------	--------------	-------------	-----------

Electrical connection rating 100 W
Current 0.8 A

Frequency (Hz) 50/60 Hz
Power supply cable length 180 cm

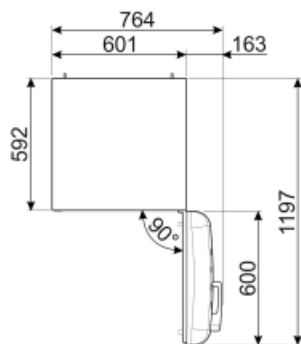
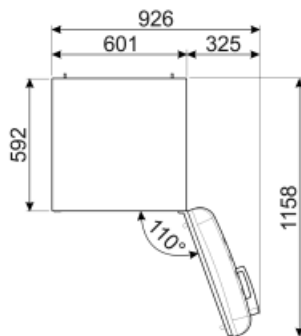
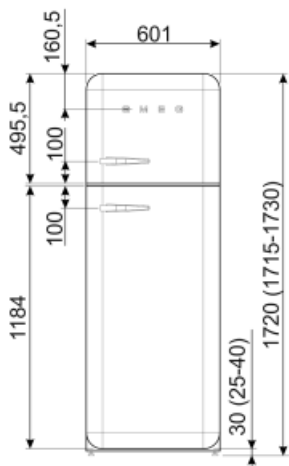
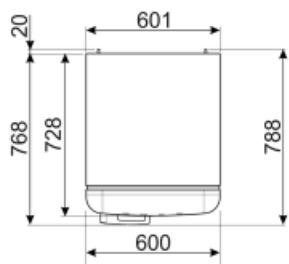

Alternative products



FAB30LPK5

Hinge position: Left
Pink



FAB30LSV5

Hinge position: Left
Silver



FAB30LBL5

Hinge position: Left
Black



FAB30LPG5

Hinge position: Left
Pastel green



FAB30RBL5

Hinge position: Right
Black



FAB30RPB5

Hinge position: Right
Pastel blue



FAB30LOR5

Hinge position: Left
Orange



FAB30RRD5

Hinge position: Right
Red



FAB30RPG5

Hinge position: Right
Pastel green



FAB30RWH5

Hinge position: Right
White



FAB30ROR5

Hinge position: Right
Orange



FAB30RPK5

Hinge position: Right
Pink



FAB30RLI5

Hinge position: Right
Lime green



FAB30LPB5

Hinge position: Left
Pastel blue



FAB30LRD5

Hinge position: Left
Red



FAB30LCR5

Hinge position: Left
Cream



FAB30RSV5

Hinge position: Right
Silver



FAB30LWH5









Hinge position: Left
White



FAB30RBE5

Hinge position: Right
Blue

Symbols glossary (TT)

- | | | | |
|--|--|---|--|
|  | 4 stars freezing compartment for better food preservation. |  | A+++: Appliances with this symbol can reduce energy consumption by a further 30% from the standard A energy rating. |
|  | Ventilated: Forced distribution of cold air in the refrigerator compartment, which allows even temperature distribution within the fridge. |  | LED interior lighting: is a more energy efficient and long lasting way of illuminating the interior of the appliance. |
|  | Life Plus 0°C: The temperature in the Lifeplus compartments is kept at 0°C, which preserves fresh meat and fish longer. |  | Smeg's evolution towards more intelligent and eco-friendly models has led to the choice of Inverter technology, which significantly reduces consumption. |
|  | Multiflow Cooling System: the Multiflow ventilation system allows an even distribution of cool air around the fridge cabinet. |  | Energy efficiency class D |