

# FAB32ULRD3



|                        |               |
|------------------------|---------------|
| <b>Product family</b>  | Refrigerator  |
| <b>Installation</b>    | Free-standing |
| <b>Category</b>        | Bottom mount  |
| <b>Reference width</b> | Until 60      |
| <b>No-frost system</b> | Total         |
| <b>Cooling type</b>    | No Frost      |
| <b>Defrost</b>         | Automatic     |
| <b>Hinge position</b>  | Left          |
| <b>EAN code</b>        | 8017709272074 |



## Aesthetic

|                      |             |                                  |           |
|----------------------|-------------|----------------------------------|-----------|
| <b>Aesthetics</b>    | Retro-style | <b>Logo</b>                      | Applied   |
| <b>Color</b>         | Red         | <b>Door shelf profile color</b>  | Chromed   |
| <b>Finishing</b>     | Glossy      | <b>Drawers profile color</b>     | Chromed   |
| <b>Handle color</b>  | Chromed     | <b>Glass shelf profile color</b> | Chromed   |
| <b>Side material</b> | Steel       | <b>Display</b>                   | 7 segment |
| <b>Side color</b>    | Red         |                                  |           |

## Refrigerator compartment features



|   |          |                              |       |
|---|----------|------------------------------|-------|
| <b>No. of adjustable shelves</b>              | 3        | <b>Type of crisper cover</b> | Glass |
| <b>Number of fruit and vegetables drawers</b> | 1        | <b>LifePlus zone - 32°F</b>  | Yes   |
| <b>Type of adjustable shelves</b>             | Glass    | <b>Refrigerator lighting</b> | Yes   |
| <b>Crisper drawer type</b>                    | Standard | <b>Refrigerator lighting</b> | LED   |
| <b>Crisper cover</b>                          | Yes      |                              |       |

## Refrigerator Inner Door

|   |   |                                   |     |
|---|---|-----------------------------------|-----|
| <b>No. of door shelves with transparent cover</b> | 1 | <b>No. of bottle shelves</b>      | 1   |
| <b>Number of adjustable door shelves</b>          | 2 | <b>Door bin with wire support</b> | Yes |

Adjustable door bins with wire support Yes

## Other Refrigerator features



Accessories  
MultiFlow

Egg tray  
Yes

Fan

Yes

## Freezer features

Number of drawers 2  
No. of compartments with flap 1

Shelf type Plastic

## Other Freezer features



Accessories

1 x ice box

Fast-freezing compartment

Yes

## Other technical features



Display functions

Holiday, Fast-freezing, Fast-cooling, ECO, Temperature alarm

Fast-freezing button

Yes

Power-on light

Yes

Temperature alarm

Yes

Door open alarm

Acoustic and visual

Temperature Alarm

Yes

Temperature setting type

Electronic

No. of compressors

1

Refrigerant gas type

R600a

Compressor type

Inverter

Refrigerant quantity

2.1 oz

Foam agent

Cyclopentane

## Performance / Energy Label NEW

Noise level 37 dB(A) re 1pW

Freezer capacity 3.99 cu. ft.

## Electrical Connection

Plug (A) USA & Mexico







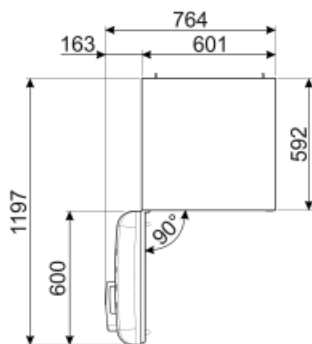
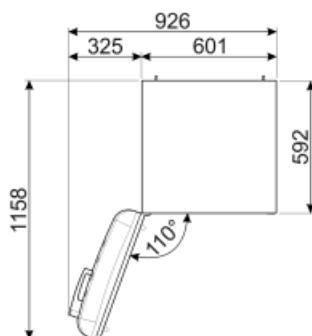
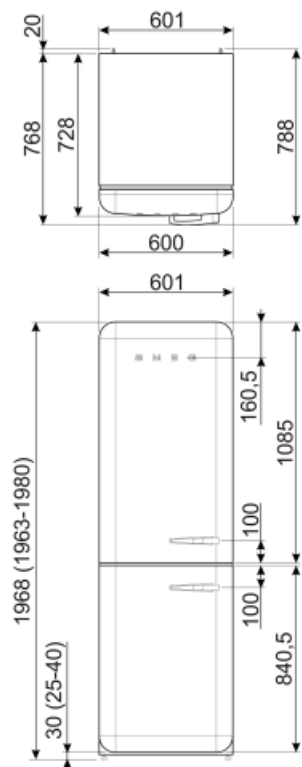



Voltage (V) 115 V

Electrical connection rating 127 W  
Current 1.2 A

Frequency (Hz) 50/60 Hz  
Power cord length 70 7/8 "



## Symbols glossary (TT)

|  |  |   |   |
|--|--|---|---|
|  | The automatic defrost system works by automatically defrosting at regular intervals eliminating the need to defrost altogether.            |  | Economical mode: Analyzes fridge functioning during the activation and optimizes the operating cycle in order to reduce power consumption.  |
|  | Ventilated: Forced distribution of cold air in the refrigerator compartment, which allows even temperature distribution within the fridge. |  | Fast freezing: The fast freezing function brings the temperature of the compartment down when activated a few hours prior to usage.   |
|  | Power saving mode: The power saving mode allows you to disable the refrigerator and keep the freezer working.                              |  | LED interior lighting: is a more energy efficient and long lasting way of illuminating the interior of the appliance.   |
|  | Life Plus 0°C: The temperature in the Lifeplus compartments is kept at 0°C, which preserves fresh meat and fish longer.                    |  | Inverter technology: The evolution of Smeg's driers towards more intelligent and environmentally sustainable models has led to the choice of using Inverter technology with heat pumps, which reduces significantly energy consumption. |
|  | Air plus: keeps food fresher for longer.   |  | No Frost: The No Frost and Frost free systems prevent ice from forming so that no defrosting is required.   |