

FAB50LBL



Product Family	Refrigerator
Installation	Free Standing
Category	Top Mount
Cooling type	No frost
Defrost	Automatic
Hinge type	Standard
Hinge position	Left
EAN code	8017709243418



Aesthetics

Aesthetics	50's Style	Handle colour	Chrome
Colour	Black	Logo colour	Chrome
Design	Rounded	Side material	Steel
Finishing	Gloss	Side colour	Black
Material	Heat-moulded	Logo	Applied
Handle	External	Display position	
Handle type	Fixed	Colori disponibili	Pastel blue, White, Cream, Red, Silver, Pastel green

Refrigerator compartment features



No. of adjustable shelves	3	Type of crisper/vegetable drawers cover	Glass
Number of fruit and vegetables drawers	2	Life Plus zone-0°C	Yes
Shelves material	Glass	Internal light in fridge	Yes
Type of crisper/vegetable drawers cover	Standard	Type of internal light (fridge)	LED
Crisper Cover	Yes		

Refrigerator Inner Door

Number of adjustable door shelves	3	No. of bottle shelves	1
-----------------------------------	---	-----------------------	---

Other Refrigerator features



Accessories	Cheese box, Butter tray, Egg tray	MultiFlow	Yes
-------------	--------------------------------------	------------------	-----

Freezer compartment features

No. of shelves	1	Type of internal light (freezer)	LED light
No. of compartments with flap	1	Type of shelves	Plastic
Internal light in freezer	Yes		

Freezer Inner Door

No. of adjustable door shelves	2
--------------------------------	---

Other Freezer features



Ice maker	Manual	Fast freezing compartment	Yes
-----------	--------	----------------------------------	-----

Other technical features



Water network connection			
Type of temperature control		Electronic	
No. of compressors		1	
Refrigerant gas type		R600a	
Type of compressor		Inverter	
Refrigerant Quantity (g)		62 g	
Foam agent		Cyclopentane	

Performance / Energy Label



Annual energy consumption	470 kWh/year	Noise level	44 dB(A) re 1 pW
Energy efficiency class	G	Thaw time	13 h
Airborne acoustical noise emission class	D	4 star - Freezing capacity	5,5 kg/24h
Total volume	440 l	Climatic class	N, ST, T
		EEl	184 %

Sum of the volumes of the frozen compartment(s) 97 l

Sum of the volumes of the chill compartment(s) and the unfrozen compartment(s) 343 l

Electrical Connection







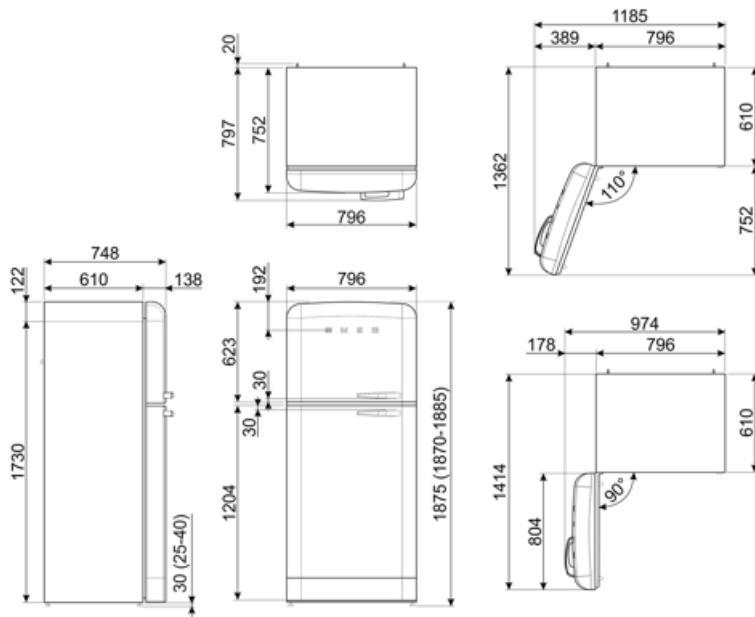

Nominal power	197 W	Frequency (Hz)	50/60 Hz
Current	1,54 A	Power supply cable length	200 cm
Voltage (V)	220-240 V	Plug	(F;E) Schuko

Logistic Information

Width (mm)	804 mm	Product width with maximum doors opening	1550 mm
Depth without handle	810 mm	Product depth with handle	780 mm
Product Height with feet	1872 mm	Product depth with doors open at 90°	1430 mm



Symbols glossary

- | | | | |
|-----------------------------------------------------------------------------------|--------------------------------------------------------------------------------------------------------------------------------------------------|-----------------------------------------------------------------------------------|-----------------------------------------------------------------------------------------------------------------------------------------------------------------------------------------------------------------------------------------|
|  | 4 stars freezing compartment for better food preservation. |  | The automatic defrost system works by automatically defrosting at regular intervals eliminating the need to defrost altogether. |
|  | A++: Energy efficiency class A++ helps to save up to 20% energy compared to class A. Maximum performance with minimum consumption is guaranteed. |  | Energy efficiency class G |
|  | Fast freezing: The fast freezing function brings the temperature of the compartment down when activated a few hours prior to usage. |  | LED interior lighting: is a more energy efficient and long lasting way of illuminating the interior of the appliance. |
|  | Life Plus 0°C: The temperature in the Lifeplus compartments is kept at 0°C, which preserves fresh meat and fish longer. |  | Inverter technology: The evolution of Smeg's driers towards more intelligent and environmentally sustainable models has led to the choice of using Inverter technology with heat pumps, which reduces significantly energy consumption. |
|  | Air plus: keeps food fresher for longer. | | |