

FAB50ULCR3



Product Family	Refrigerator
Installation	Free standing
Category	Double Door
Cooling type	Total No Frost - Double Cooling system
Defrost	Automatic
Hinge position	Left
EAN code	8017709321482



Aesthetics



Aesthetic	50's Style	Side colour	Cream
Colour	Cream	Logo	Applied
Finishing	Glossy	Door shelves profile color	Silver
Handle	External	Drawers profile color	Silver
Handle colour	Chrome	Color of glass shelf profile	Chrome
Logo colour	Chrome	Display	LED
Side material	Steel	Display position	Interno (cella frigo)

Refrigerator compartment features



No. of adjustable shelves	2	Type of crisper/vegetable drawers cover	Glass
Number of fruit and vegetables drawers	1	Life Plus zone-0°C	Yes
Type of adjustable shelves	Glass	Type of internal light (fridge)	LED
Crisper Cover	Yes		

Refrigerator Inner Door

Number of adjustable door shelves	3	No. of bottle shelves	1
-----------------------------------	---	-----------------------	---

Other Refrigerator features



MultiFlow

Yes

Fan

Yes

Freezer compartment features

No. of shelves

1

Type of internal light
(freezer)

LED

Internal light in freezer

Yes

Type of shelves

Glass

Freezer Inner Door

No. of adjustable door
shelves

2

Other Freezer features



Manual ice maker
Ice maker

Yes

Automatic

Fast freezing
compartment

Yes

Other technical features



Functions display

Fast freezing, ECO, Temperature alarm

Fast freezing button

Yes

Door open alarm

Acoustic and visual

Type of temperature control

Electronic

No. of compressors

1

Refrigerant gas type

R600a

Type of compressor

Inverter

Foam agent

Cyclopentane

Performance / Energy Label - Reg. 2019

Annual energy
consumption

453 kWh/year

Airborne acoustical
noise emissions

41 dB(A) re 1 pW

Sum of the volumes of
the frozen
compartment(s)

4.38 cu. ft.

Fresh Food
compartment - Gross
Volume

14.90 cu. ft.

Total gross volume

19.28 cu. ft.

Climate class







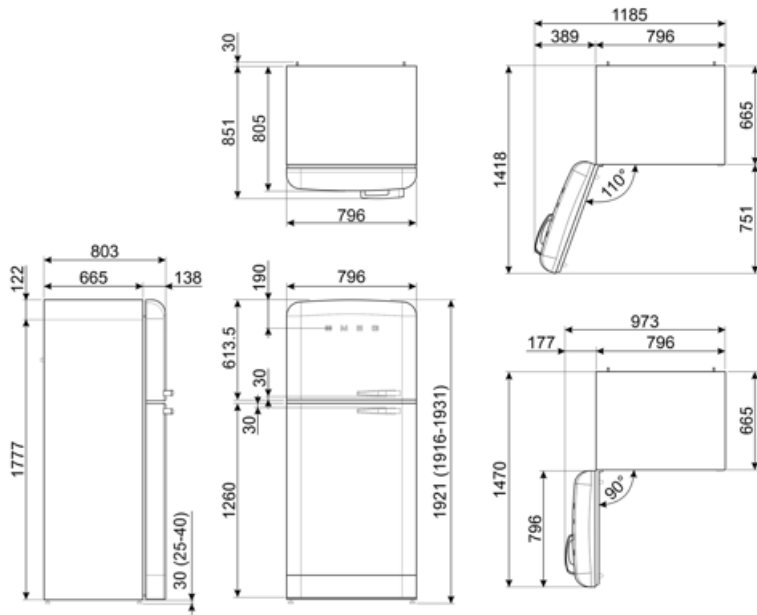

SN, N, ST, T

Electrical Connection

Plug	(A) USA e Messico	Voltage (V)	120 V
Electrical connection rating	197 W	Frequency (Hz)	60 Hz
Current	2.6 A	Power supply cable length	70 7/8 "



Symbols glossary (TT)

	The automatic defrost system works by automatically defrosting at regular intervals eliminating the need to defrost altogether.		LED display: to show programmes, functions and options selected and the time to the end of the cycle.
	Economical mode: Analyzes fridge functioning during the activation and optimizes the operating cycle in order to reduce power consumption.		Ventilated: Forced distribution of cold air in the refrigerator compartment, which allows even temperature distribution within the fridge.
	Fast freezing: The fast freezing function brings the temperature of the compartment down when activated a few hours prior to usage.		LED interior lighting: is a more energy efficient and long lasting way of illuminating the interior of the appliance.
	Life Plus 0°C: The temperature in the Lifeplus compartments is kept at 0°C, which preserves fresh meat and fish longer.		Smeg's evolution towards more intelligent and eco-friendly models has led to the choice of Inverter technology, which significantly reduces consumption.
	Air plus: keeps food fresher for longer.		