

# FAB50URCRB3



Product Family	Refrigerator
Installation	Free standing
Category	Double Door
Sistema Total No - Frost	Yes
Cooling type	Total No Frost - Double Cooling system
Defrost	Automatic
Hinge position	Right
EAN code	8017709321529



## Aesthetics



Aesthetic	50's Style	Logo	Applied
Colour	Cream	Door shelves profile color	Silver
Finishing	Glossy	Drawers profile color	Silver
Handle	External	Color of glass shelf profile	Chrome
Handle colour	Antique brass	Display	LED
Logo colour	Antique brass	Display position	Interno (cella frigo)
Side material	Steel	Water Filter	Yes
Side colour	Cream		

## Refrigerator compartment features



Number of compartments	2	Crisper Cover	Yes
Compartment types	Low temperature compartment, Fruit and vegetable compartment	Type of crisper/vegetable drawers cover	Glass
No. of adjustable shelves	2	Low temperature compartment	Yes
Number of fruit and vegetables drawers	1	Type of internal light (fridge)	LED
Shelves material	Glass		

## Refrigerator Inner Door

Number of adjustable door shelves	3	No. of bottle shelves	1
-----------------------------------	---	-----------------------	---

## Other Refrigerator features



Humidity Control	Yes	MultiFlow	Yes
------------------	-----	-----------	-----

## Freezer compartment features

No. of shelves	1	Type of internal light (freezer)	LED
Internal light in freezer	Yes	Type of shelves	Glass

## Freezer Inner Door

No. of adjustable door shelves	2
--------------------------------	---

## Other Freezer features



Ice maker	Automatic	Ice shape	Cubes
Daily ice production	1.8 kg	Fast freezing compartment	Yes

## Other technical features



Functions display	Fast freezing, ECO, Temperature alarm
Fast freezing button	Yes
Water network connection	Yes
Door open alarm	Acoustic and visual
Temperature Alarm	Yes
Type of temperature control	Electronic
No. of compressors	1
Refrigerant gas type	R600a
Type of compressor	Inverter
No. of evaporators	2
Foam agent	Cyclopentane

## Performance / Energy Label - Reg. 2019

Annual energy consumption	453 kWh/year
---------------------------	--------------

<b>Total gross volume</b>	19.3 cu. ft.	<b>Fresh Food compartment - Gross Volume</b>	14.9 cu. ft.
<b>Airborne acoustical noise emissions</b>	41 dB(A) re 1 pW	<b>Climate class</b>	SN, N, ST, T

## Electrical Connection

<b>Electrical connection rating</b>	215 W	<b>Frequency (Hz)</b>	60 Hz
<b>Current</b>	2.6 A	<b>Power supply cable length</b>	70 7/8 "
<b>Voltage (V)</b>	120 V	<b>Plug</b>	(B) NEMA 5-15P

## Logistic Information

<b>Width</b>	31 5/16 "	<b>Product width with maximum doors opening</b>	46 5/8 "
<b>Depth without handle</b>	31 11/16 "	<b>Product depth with handle</b>	33 1/2 "
<b>Height</b>	75 5/8 "	<b>Product depth with doors open at 90°</b>	57 7/8 "

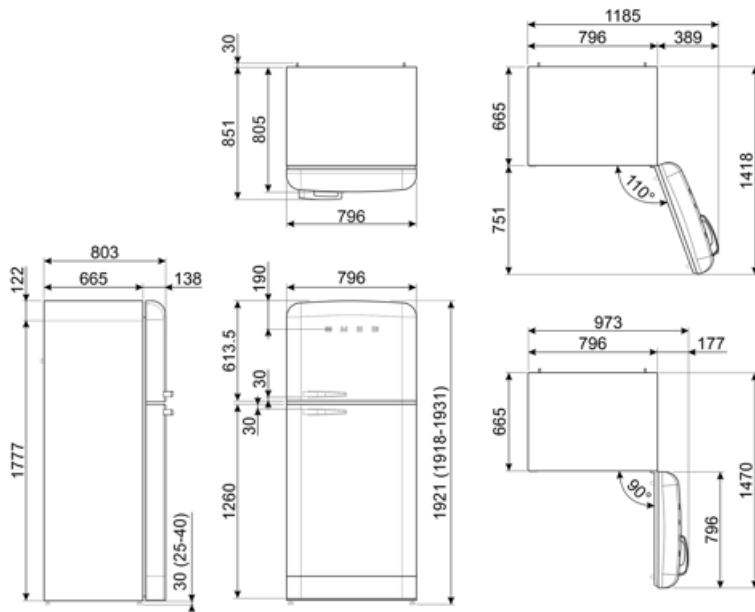

---

## Alternative products

---



**FAB50URWH3**

**Hinge position:** Right  
White



**FAB50URCR3**

**Hinge position:** Right  
Cream



**FAB50URRD3**

**Hinge position:** Right  
Red



**FAB50URPG3**

**Hinge position:** Right  
Pastel green



**FAB50URPB3**











**Hinge position:** Right  
Pastel blue



**FAB50URBL3**

**Hinge position:** Right  
Black

## Symbols glossary

- |  |  |   |  |
|--|--|---|--|
|  | 4 stars freezing compartment for better food preservation.   |  | The automatic defrost system works by automatically defrosting at regular intervals eliminating the need to defrost altogether.            |
|  | A++: Energy efficiency class A++ helps to save up to 20% energy compared to class A. Maximum performance with minimum consumption is guaranteed.         |  | Energy efficiency class E  |
|  | LED display: to show programmes, functions and options selected and the time to the end of the cycle.  |  | Economical mode: Analyzes fridge functioning during the activation and optimizes the operating cycle in order to reduce power consumption. |
|  | Fast freezing: The fast freezing function brings the temperature of the compartment down when activated a few hours prior to usage.                      |  | LED interior lighting: is a more energy efficient and long lasting way of illuminating the interior of the appliance.                      |
|  | Smeg's evolution towards more intelligent and eco-friendly models has led to the choice of Inverter technology, which significantly reduces consumption. |  | Air plus: keeps food fresher for longer.   |