

# FAB50URWH3



Product Family	Refrigerator
Installation	Free standing
Category	Double Door
Cooling type	Total No Frost - Double Cooling system
Defrost	Automatic
Hinge position	Right
EAN code	8017709321505



## Aesthetics



Aesthetic	50's Style	Side colour	White
Colour	White	Logo	Applied
Finishing	Glossy	Door shelves profile color	Silver
Handle	External	Drawers profile color	Silver
Handle colour	Chrome	Color of glass shelf profile	Chrome
Logo colour	Chrome	Display	LED
Side material	Steel	Display position	Interno (cella frigo)

## Refrigerator compartment features



No. of adjustable shelves	2	Type of crisper/vegetable drawers cover	Glass
Number of fruit and vegetables drawers	1	Life Plus zone-0°C	Yes
Type of adjustable shelves	Glass	Type of internal light (fridge)	LED
Crisper Cover	Yes		

## Refrigerator Inner Door

Number of adjustable door shelves	3	No. of bottle shelves	1
-----------------------------------	---	-----------------------	---

## Other Refrigerator features



MultiFlow

Yes

Fan

Yes

## Freezer compartment features

No. of shelves 1  
Internal light in freezer Yes

Type of internal light (freezer) LED  
Type of shelves Glass

## Freezer Inner Door

No. of adjustable door shelves 2

## Other Freezer features



Manual ice maker Yes  
Ice maker Automatic

Fast freezing compartment Yes

## Other technical features



Functions display	Fast freezing, ECO, Temperature alarm
Fast freezing button	Yes
Door open alarm	Acoustic and visual
Type of temperature control	Electronic
No. of compressors	1
Refrigerant gas type	R600a
Type of compressor	Inverter
Foam agent	Cyclopentane

## Performance / Energy Label - Reg. 2019

Annual energy consumption	453 KWh/year	Airborne acoustical noise emissions	41 dB(A) re 1 pW
Sum of the volumes of the frozen compartment(s)	4.38 cu. ft.	Fresh Food compartment - Gross Volume	14.90 cu. ft.
Total gross volume	19.28 cu. ft.	Climate class	SN, N, ST, T







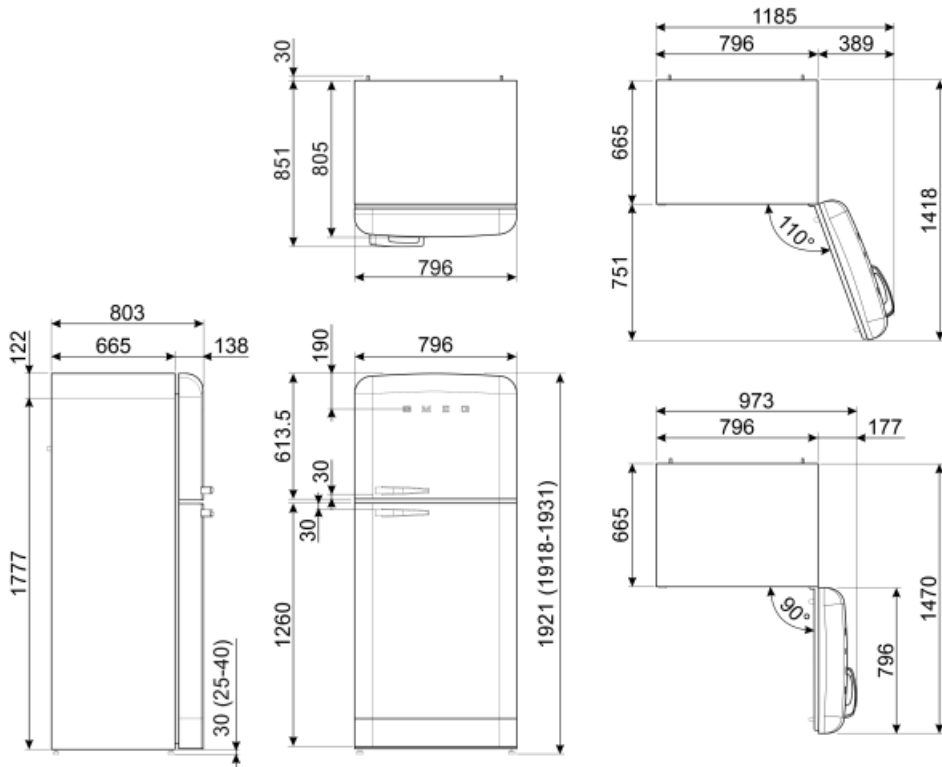

## Electrical Connection

**Plug** (A) USA e Messico  
**Electrical connection rating** 197 W  
**Current** 2,6 A

**Voltage (V)** 120 V  
**Frequency (Hz)** 60 Hz  
**Power supply cable length** 70 7/8 "



## Symbols glossary (TT)

	The automatic defrost system works by automatically defrosting at regular intervals eliminating the need to defrost altogether.		LED display: to show programmes, functions and options selected and the time to the end of the cycle.
	Economical mode: Analyzes fridge functioning during the activation and optimizes the operating cycle in order to reduce power consumption.		Ventilated: Forced distribution of cold air in the refrigerator compartment, which allows even temperature distribution within the fridge.
	Fast freezing: The fast freezing function brings the temperature of the compartment down when activated a few hours prior to usage.		LED interior lighting: is a more energy efficient and long lasting way of illuminating the interior of the appliance.
	Life Plus 0°C: The temperature in the Lifeplus compartments is kept at 0°C, which preserves fresh meat and fish longer.		Smeg's evolution towards more intelligent and eco-friendly models has led to the choice of Inverter technology, which significantly reduces consumption.
	Air plus: keeps food fresher for longer.		