

# FAB5LOR5



Product Family	Refrigerator
Installation	Free standing
Category	One Door
Reference width	Until 60
Reference height	Until 100
Cooling type	Static
Defrost	Automatic
Hinge type	Standard
Hinge position	Left
EAN code	8017709299477



## Aesthetics

Aesthetic	50's Style	Logo colour	Chrome
Colour	Orange	Side material	Steel
Finishing	Glossy	Side colour	Orange
Design	Rounded	Logo	Applied
Material	Heat-moulded	Door shelves profile color	Chrome
Handle	External	Drawers profile color	Chrome
Handle type	Fixed	Color of glass shelf profile	Chrome
Handle colour	Chrome		

## Refrigerator compartment features



No. of adjustable shelves	2	Internal light in fridge	Yes
Type of adjustable shelves	Glass	Type of internal light (fridge)	LED

## Refrigerator Inner Door

Number of adjustable door shelves	1	No. of bottle shelves	1
Adjustable door shelves with wire support	Yes	Bottle shelves with wire support	Yes

## Other technical features

Type of temperature control	Electronic
Refrigerant gas type	R600a
Type of compressor	Standard
Refrigerant Quantity (gr)	19 g
Foam agent	Cyclopentane

## Performance / Energy Label - Reg. 2019

			
Annual energy consumption	61 kWh/a	Sum of the volumes of the chill compartment(s) and the unfrozen compartment(s)	34 l
Energy efficiency class	D	Airborne acoustical noise emissions	40 dB(A) re 1 pW
Airborne acoustical noise emission class	C	Climate class	SN, N, ST, T
Total net volume	34 l	EI	79 %

## Electrical Connection

Plug	(F;E) Schuko	Voltage (V)	220-240 V
Electrical connection rating	60 W	Frequency (Hz)	50/60 Hz
Current	0.3 A	Power supply cable length	100 cm

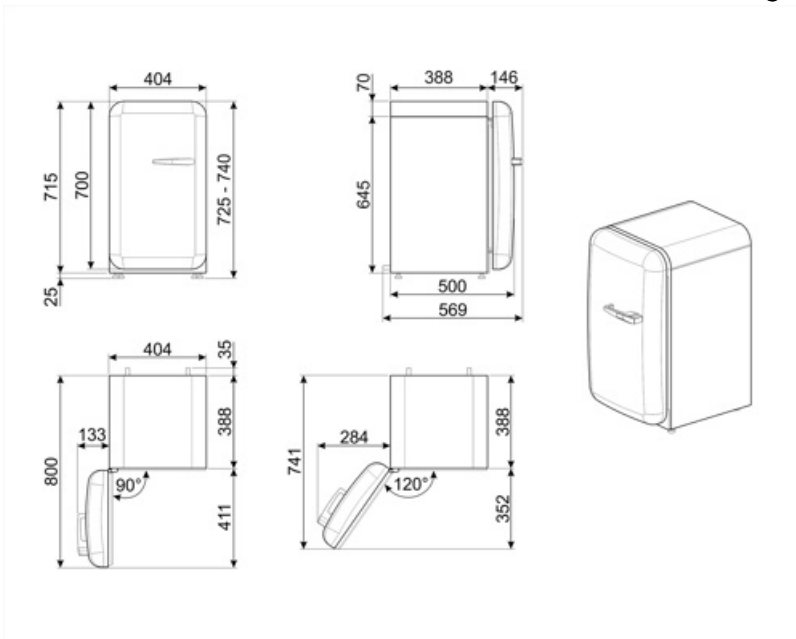

---

## Compatible Accessories

---

**KITCABLE90UK**

Cable with IEC connector and UK plug

---

## Alternative products

---



**FAB5LRD5**

**Hinge position:** Left  
Red



**FAB5LPG5**

**Hinge position:** Left  
Pastel green



**FAB5LWH5**

**Hinge position:** Left  
White



**FAB5LCR5**

**Hinge position:** Left  
Cream



**FAB5LSV5**

**Hinge position:** Left  
Silver



**FAB5LPK5**

**Hinge position:** Left  
Pink



**FAB5LPB5**

**Hinge position:** Left  
Pastel blue







**FAB5LBL5**

**Hinge position:** Left  
Black

---

## Symbols glossary

---

- |  |   |   |   |
|--|---|---|---|
|  | A+++: Appliances with this symbol can reduce energy consumption by a further 30% from the standard A energy rating.   |  | The automatic defrost system works by automatically defrosting at regular intervals eliminating the need to defrost altogether. |
|  | LED interior lighting: is a more energy efficient and long lasting way of illuminating the interior of the appliance. |  | Energy efficiency class D   |

---

## Benefit (TT)

---

### **Refrigerant gas R600a**

Environmentally friendly R600a refrigerant gas contributes to rapid cooling with lower energy consumption

### **Climate class**

Climatic class SN-T makes the appliance suitable for working at room temperature between 10 °C and 43 °C (50 °F ~ 109 °F)

### **External handle**

The external handle ensures practicality and ease of use of the refrigerator

### **Refrigerator Internal lighting**

Interior lighting for perfect visibility of shelves in the refrigerator compartment